

Neles™ V-port segment valve RA-series

Neles V-port valve in the R-series is primarily intended as a control valve, but it can also be used for shut-off service. The R-series V-port segment valve is a good general control valve for most pulp and paper process applications. The valve can be fitted with an aerodynamic noise- and liquid cavitation-reducing (for example, steam and gas applications) Q-Trim™ segment. A low capacity segment is available for the DN25 valve.



Features

Single-piece valve body

- R-series valves have single-piece bodies, which prevents leaks caused by separate flanges or locking rings.

Durable metal seat

- The seat of the R-series V-port segment valve is firm and uniquely durable. The seat is designed in such a way that its sealing surface is not located directly in the flow stream. This gives the seat an extended service life. The working principle is a pressure-aided seat which enables good sealing properties at a low pressure difference. The seat is located inside the valve, which prevents forces from the pipe system influencing the sealing effect.

PTFE seat

- The R-series V-port segment valve is also available with a soft seat. This is primarily intended for applications where a hard chromium plated segment is unsuitable, e.g. for acids and acidic liquids. This structure contains an Xtreme™ seat, fitted in a body made of stainless steel.

Bearings

- The bearings are located in the valve body, away from the flow stream, with a large bearing surface, offering a low bearing pressure and a long service life.

Smooth action

- Because of the double bearing, the pre-tightened spring-loaded gland packing, and the low seat friction, the torque requirement of the R-series V-port segment valve is low. For this reason the size of actuator required is small. As a consequence, the control valve package combines low overall costs with good control performance.

Q-Trim™

- Most pulp and paper mills have maximum noise levels for control valves. These limits are easily exceeded, especially for gas and steam applications, when using standard valves. High pressure drops, which occur during control of water and liquid flows, generate cavitation which may cause damage to the pipe system. The solution to these applications is the Q-Trim design. Impurities will not block the valve because of the self-cleaning design. The design can be used for media such as impure steam, black liquor, and even 3.5 % pulp.

Low capacity

- Four different low capacity C_v trims are available for the DN25 valve. These enable high accuracy control of small flows. Typical applications are, for example, dyes and other additives on a paper machine.

Exploded view

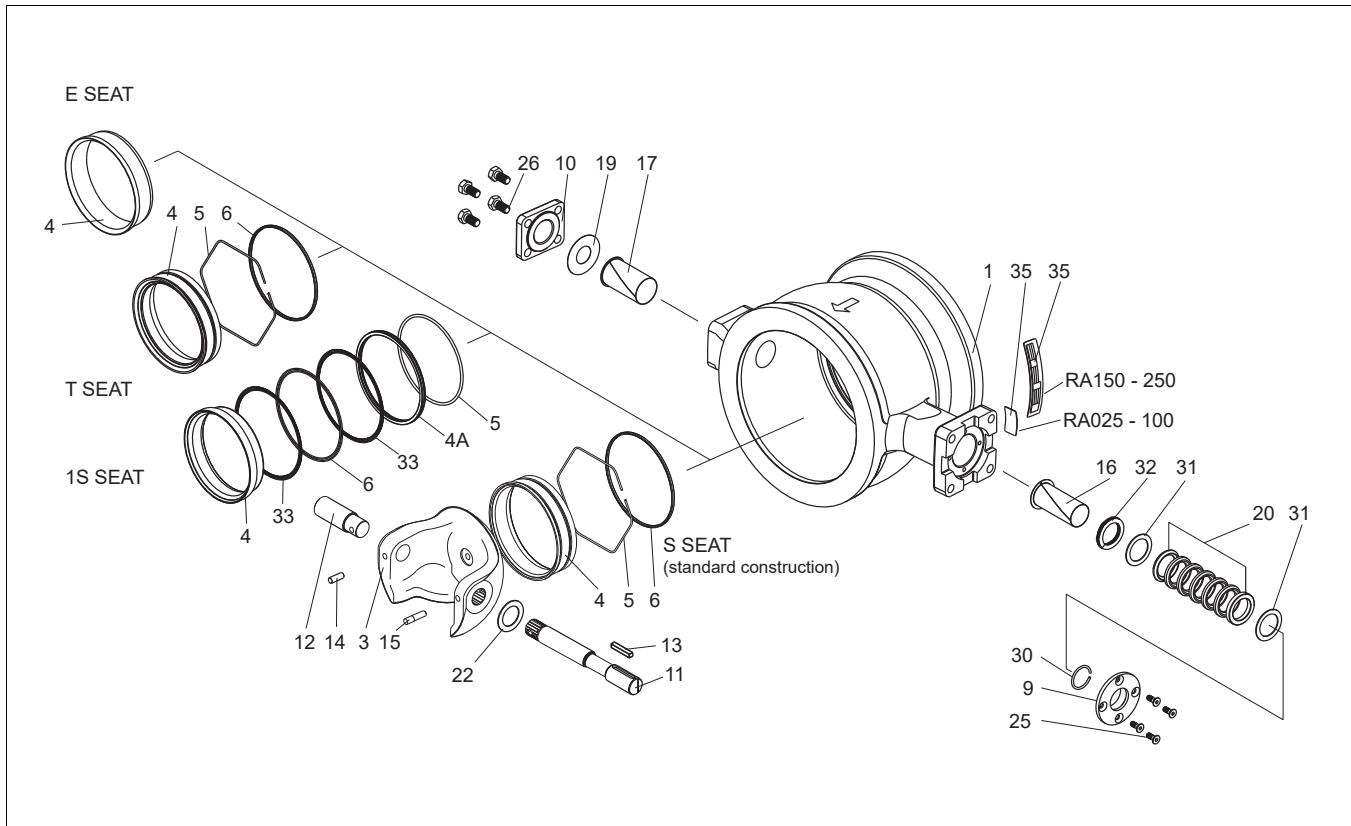

Parts list (standard construction)*

Part	Name	Body material
1	Body	ASTM A351 gr. CF8M
3	V-port segment	SIS 2324 + chromium / SIS 2324 / AISI 329
4	Seat	Cobalt based alloy / PTFE 1)
4A	Back ring	AISI 316
5	Lock spring	INCONEL 625
6	Back seal	Stainless steel + PTFE
9	Gland follower	ASTM A351 gr. CF8M
10	Blind flange	ASTM A351 gr. CF8M
11	Drive shaft	SIS 2324/AISI 329 duplex SS
12	Shaft	SIS 2324/AISI 329 duplex SS
13	Key	SIS 2324/AISI 329
14	Cylindrical pin	SIS 2324/AISI 329
15	Cylindrical pin	SIS 2324/AISI 329
16	Bearing	PTFE + SS net
17	Bearing	PTFE + SS net
19	Sealing plate	Graphite
20	Packing	PTFE
22	Filling ring (only low Cv 1"/DN 25)	Stainless Steel AISI 316
25	Countersunk screw	ISO 3506 A2-70
26	Hexagon bolt	ISO 3506 A2-70
30	Retainer ring	AISI 316
31	Sheet ring	AISI 316
32	Wave spring	AISI 316
35	Identification plate	AISI 304

* The parts are not in number order since certain part has dedicated part number.

TECHNICAL SPECIFICATIONS

Type

Reduced-bore quarter-turn valve
– RA mounted between flanges

Pressure ratings

Body

RA: ASME 300 / PN 40

Trim: See table below

Valve size DN / inch	Max. shut-off dp, (bar)
025 / 1"	50
040 / 1 1/2"	50
050 / 2"	50
065 / 2 1/2"	50
080 / 3"	50
100 / 4"	40
150 / 6"	40
200 / 8"	35
250 / 10"	35

Size

RA: DN25, 40, 50, 65, 80, 100, 150, 200, 250

Face-to-face dimensions

RA According to internal standard

Temperature range

-40... +260 °C.

Inherent flow characteristic

Equal percentage.

Tightness

Tightness testing is done in the flow direction. The standard tightness of the metal-seated V-port segment valve is ANSI/FCI 70.2 Class IV.

Pressure and tightness testing of the valve

Every valve manufactured by Valmet is subjected to a body pressure test and a trim tightness test. The test pressure of a R-series body is 1.5 x the maximum operating pressure. The pressure of the tightness test is 3,5 barG according to IEC 60534 / ANSI/FCI 702 Class IV. The testing medium is water.

Maximum C_v -values for RA series valves

Size		Metal seat, S	Q-Trim	Metal seat, 1S	Q-Trim with 1S	Soft seat, T2
DN	Inch	C_v 100 % ¹⁾	C_v 100 % ²⁾	C_v 100 % ¹⁾	C_v 100 % ²⁾	C_v 100 % ¹⁾
25	1	45	-	24	-	21
40	1 1/2	110	-	58	-	61
50	2	163	47	115	30	110
65	2 1/2	280	96	210	72	215
80	3	420	160	342	130	340
100	4	620	250	510	210	520
150	6	1260	540	1160	500	1070
200	8	2030	880	1910	830	1760
250	10	3210	1510	3050	1440	2830

1) 100 % corresponds to 95° turning angle

2) For Q-R-valves, 100 % corresponds to 90° turning angle

Maximum operating pressure differential in shut-off service

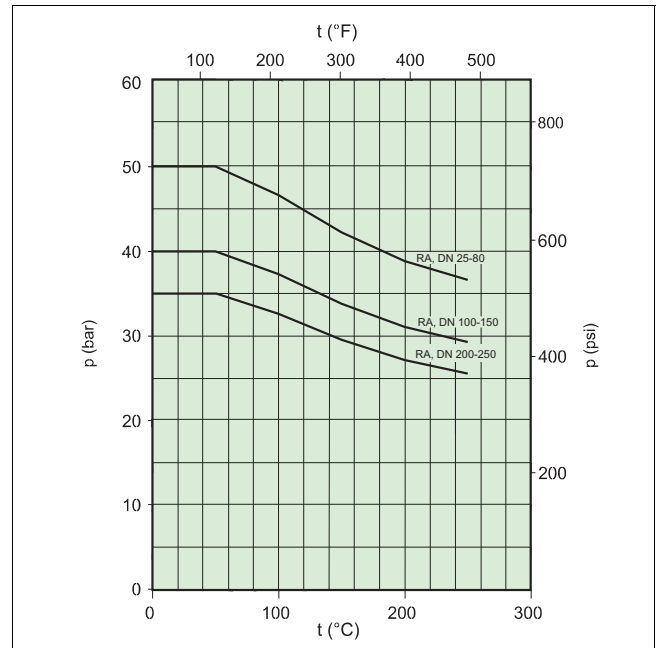

Maximum body pressure for standard A 351 gr. CF8M material

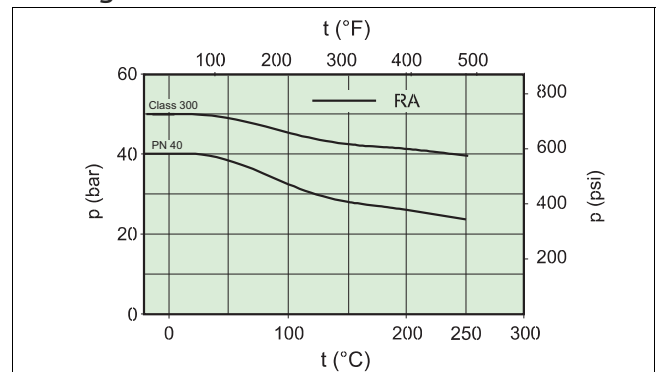

Note that max. throttling pressures are mechanical maximum differential pressures at ambient temperature.

In practice you must always check temperature, actuator, load factor, noise, cavitation intensity, velocity, etc. from Nelprof™ sizing and selection software.

**Max operating pressure differential in control service,
RA opening range 0 %-70 %**

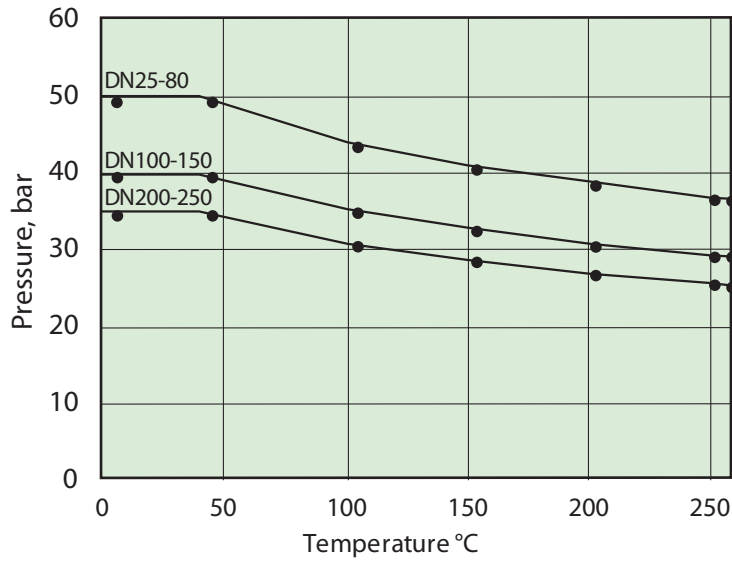

**Max operating pressure differential in control service,
RA opening range 70 %-100 %**

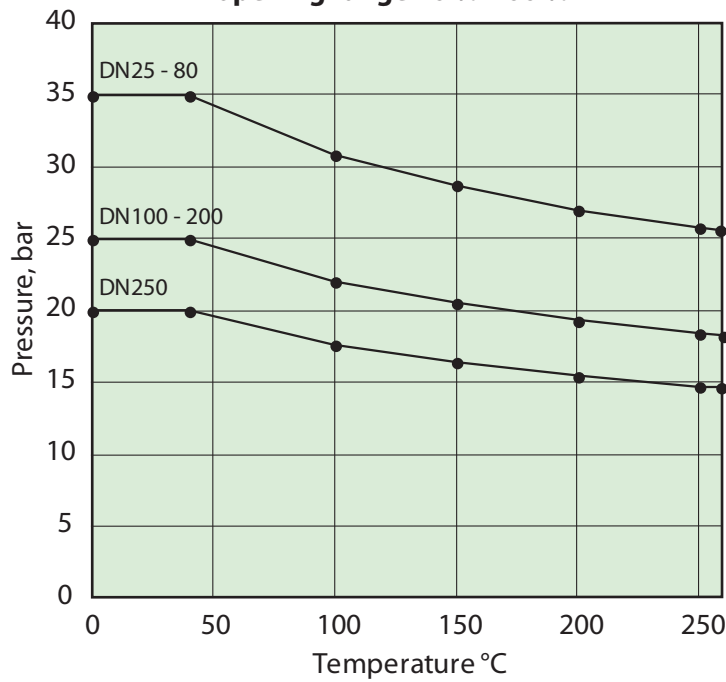

**Max operating pressure differential in control service,
Q-RA opening range 0 %- 30 %**

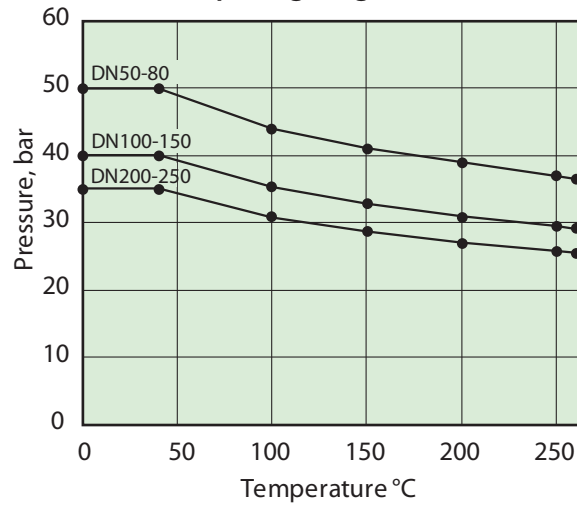

**Max operating pressure differential in control service,
Q-RA opening range 30 %- 60 %**

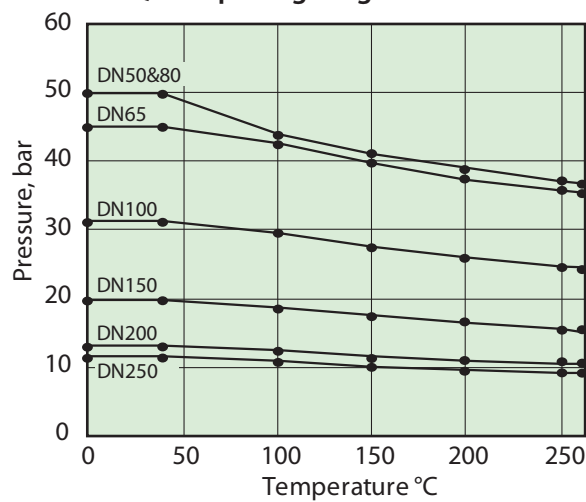

**Max operating pressure differential in control service,
Q-RA opening range 60 %-100 %**

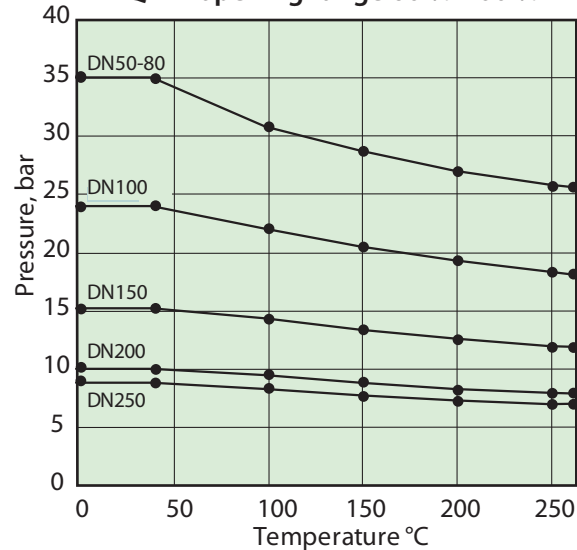

Seats design

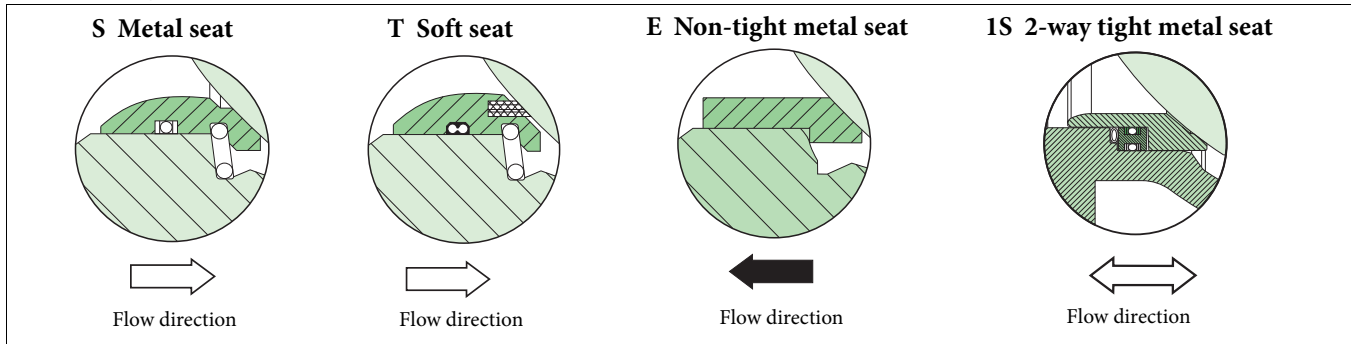

Actuator selection, R-series valve

Valve/actuator sizes have been pre-selected. You will find them on pages 7 - 11. The valve/actuator size must be checked with the Nelprof program for each control valve.

Maximum allowed stem torque

Valve size		Torque	
DN	Inches	Nm	ft-lb
25	1	30	22
40	1.5	30	22
50	2	65	48
65	2.5	65	48
80	3	160	118
100	4	160	118
150	6	490	362
200	8	675	498
250	10	1350	996

S seat

Seat	Stainless steel + cobalt based hard facing
Spring	Inconel 625
Seat seal	Filled PTFE lip seal/Elgiloy spring
Temperature range	-40 °C... +260 °C / - 40 °F ...+500 °F
Service	General service

T Soft seat (PTFE + C25 %)

Code	Seat body	Spring	Seat seal	Back seal
T2	316 SS	Inconel 625	DN 25 - 150 X-treme DN 200 - 250 filled PTFE	PTFE
Temperature range T2, -40 °C... +260 °C / -40 °F ...+500 °F				

E Non-tight metal seat

Seat	Cobalt based alloy
Temperature range	-40 °C... +260 °C / - 40 °F ...+500 °F
Service	Erosive applications, non-tight design.
Note!	Flow direction arrow is reversed.

1S 2-way tight metal seat

Seat:	316 SS + Cobalt based hard facing
Spring:	Inconel 625
Seat seal:	Viton GF
Temp. range:	-30 °C... +200 °C / -22 °F ...+186 °F
Service:	General

Torque chart

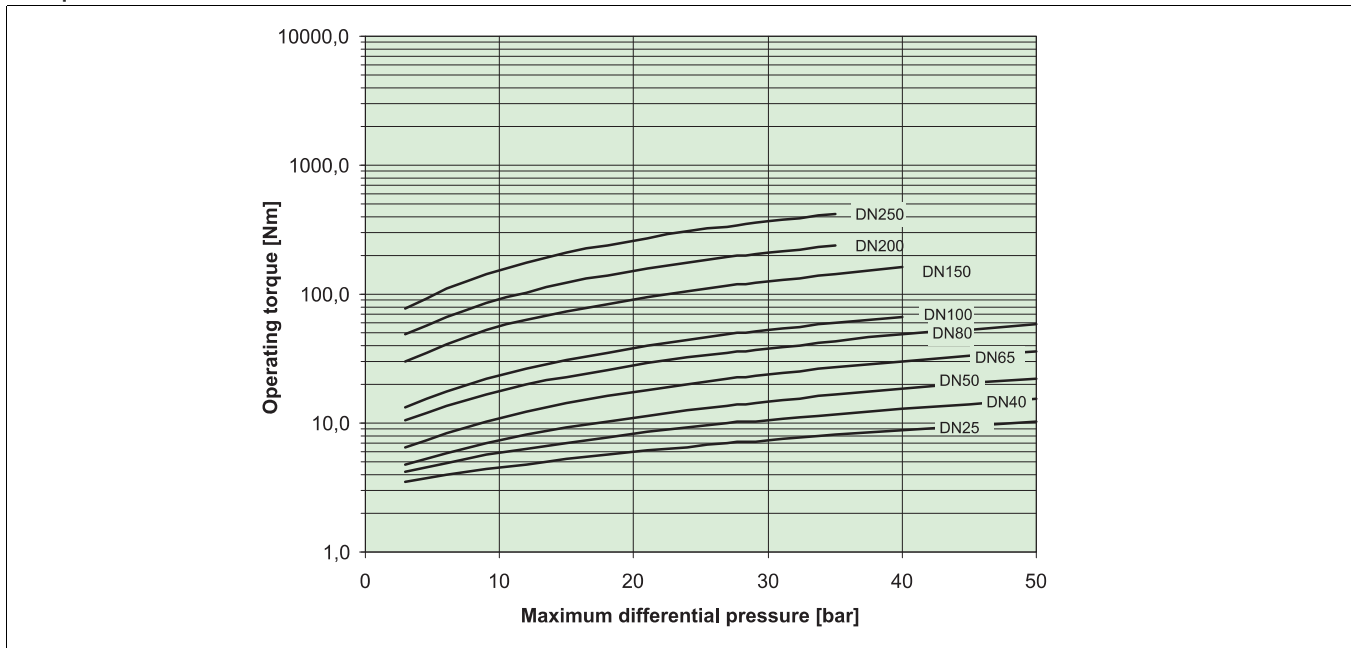

DIMENSIONS

RA

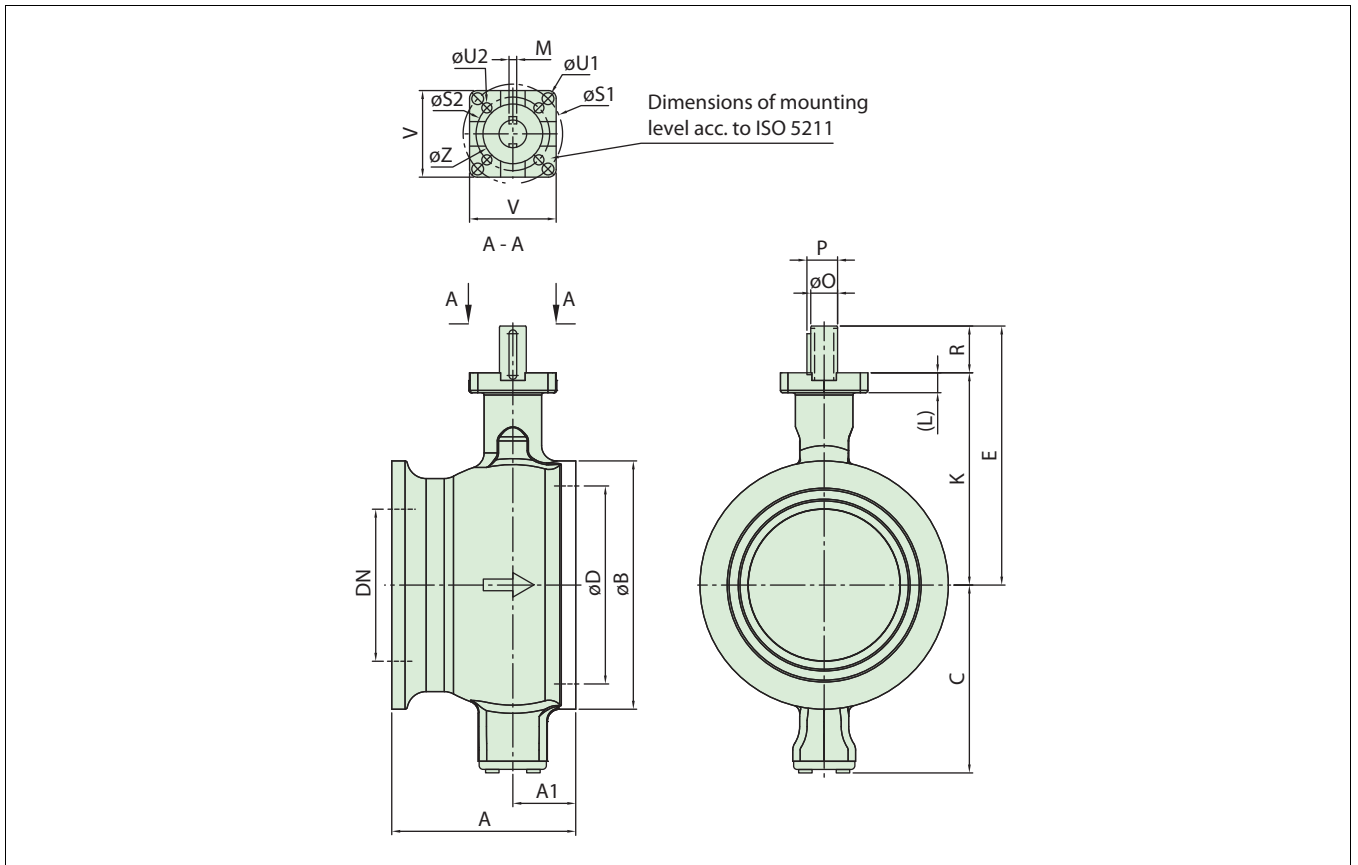

Type	DN	ISO 5211	Dimensions, mm																	Kg	
			A1	A	ϕB	C	ϕD	E	R	K	ϕO	M	P	$\phi S1$	$\phi S2$	$\phi U1$	$\phi U2$	ϕZ	L		V
RA	25	F05	21	50	64	56	33	127	27	102	15	4.76	17	-	50	-	6.6	35	15.5	52	1.3
	40	F05	21	60	82	65	49	133.5	25	108.5	15	4.76	17	-	50	-	6.6	35	15.5	52	2.4
	50	F05, F07	27	75	100	91	60	144.5	25	119.5	15	4.76	17	70	50	9	6.6	55	15.5	67	3.7
	65	F05, F07	40	100	118	97	75	151	25	126	15	4.76	17	70	50	9	6.6	55	15.5	67	5.3
	80	F07, F10	38	100	130	108	89	177	35	142	20	4.76	22.2	102	70	11	9	70	16	94	6.2
	100	F07, F10	41	115	158	120	115	186	35	151	20	4.76	22.2	102	70	11	9	70	16	94	9.6
	150	F10, F12	55	160	216	174	164	244	44	200	25	6.35	27.8	125	102	14	11	85	22	114	24
	200	F10, F12	70	200	268	201	205	289	54	235	30	6.35	32.9	125	102	14	11	85	22	114	42
	250	F12, F14	82	240	324	251	259	338	61	277	35	9.53	39.1	140	125	18	14	100	26	136	68

RA-B1C

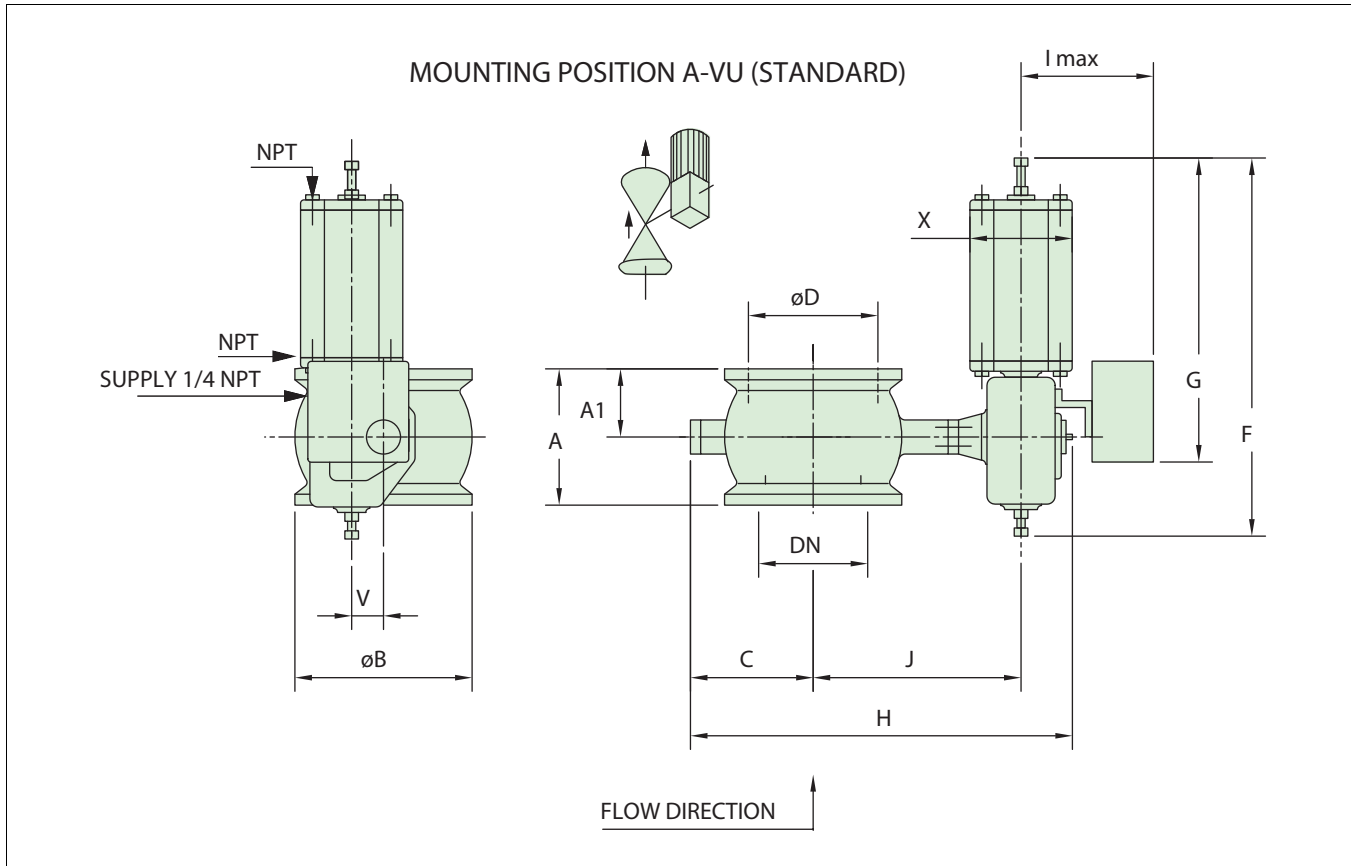

Type	Max. Δp 1)	Dimensions [mm]												NPT	Kg	
		DN	A	A1	B	C	D	F	G	X	V	J	H			I max
RA_025-B1C6	50	25	50	21	64	56	33	400	260	90	36	168	305	310	1/4	5,5
RA_040-B1C6	50	40	60	21	82	65	49	400	260	90	36	175	320	310	1/4	6,6
RA_050-B1C6	50	50	75	27	100	91	60	400	260	90	36	185	355	310	1/4	8
RA_050-B1C9	50	50	75	27	100	91	60	455	315	110	43	185	365	305	1/4	13,5
RA_065-B1C6	50	65	100	40	118	97	75	400	260	90	36	192	367	310	1/4	9,5
RA_065-B1C9	50	65	100	40	118	97	75	455	315	110	43	192	380	305	1/4	15
RA_080-B1C6	50	80	100	38	130	108	89	400	260	90	36	200	390	310	1/4	11
RA_080-B1C9	50	80	100	38	130	108	89	455	315	110	43	200	400	305	1/4	16
RA_100-B1C6	40	100	115	41	158	120	115	400	260	90	36	210	410	310	1/4	15
RA_100-B1C9	40	100	115	41	158	120	115	455	315	110	43	210	420	305	1/4	19
RA_150-B1C9	25	150	160	55	216	174	164	455	315	110	43	260	515	305	1/4	34
RA_150-B1C11	40	150	160	55	216	174	164	540	375	135	51	265	530	310	3/8	40
RA_150-B1C13	40	150	160	55	216	174	164	635	445	175	65	280	550	325	3/8	55
RA_200-B1C9	15	200	200	70	268	201	205	455	315	110	43	294	575	305	1/4	52
RA_200-B1C11	32	200	200	70	268	201	205	540	375	135	51	310	590	310	3/8	59
RA_200-B1C13	35	200	200	70	268	201	205	635	445	175	65	325	610	325	3/8	73
RA_250-B1C13	30	250	240	82	324	251	259	635	445	175	65	366	730	325	3/8	100
RA_250-B1C17	35	250	240	82	324	251	259	770	545	215	78	373	750	340	3/8	125

1) Max Δp in on-off service with actuator load factor 0.6 and supply pressure 5 bar

RA - B1J, B1JA

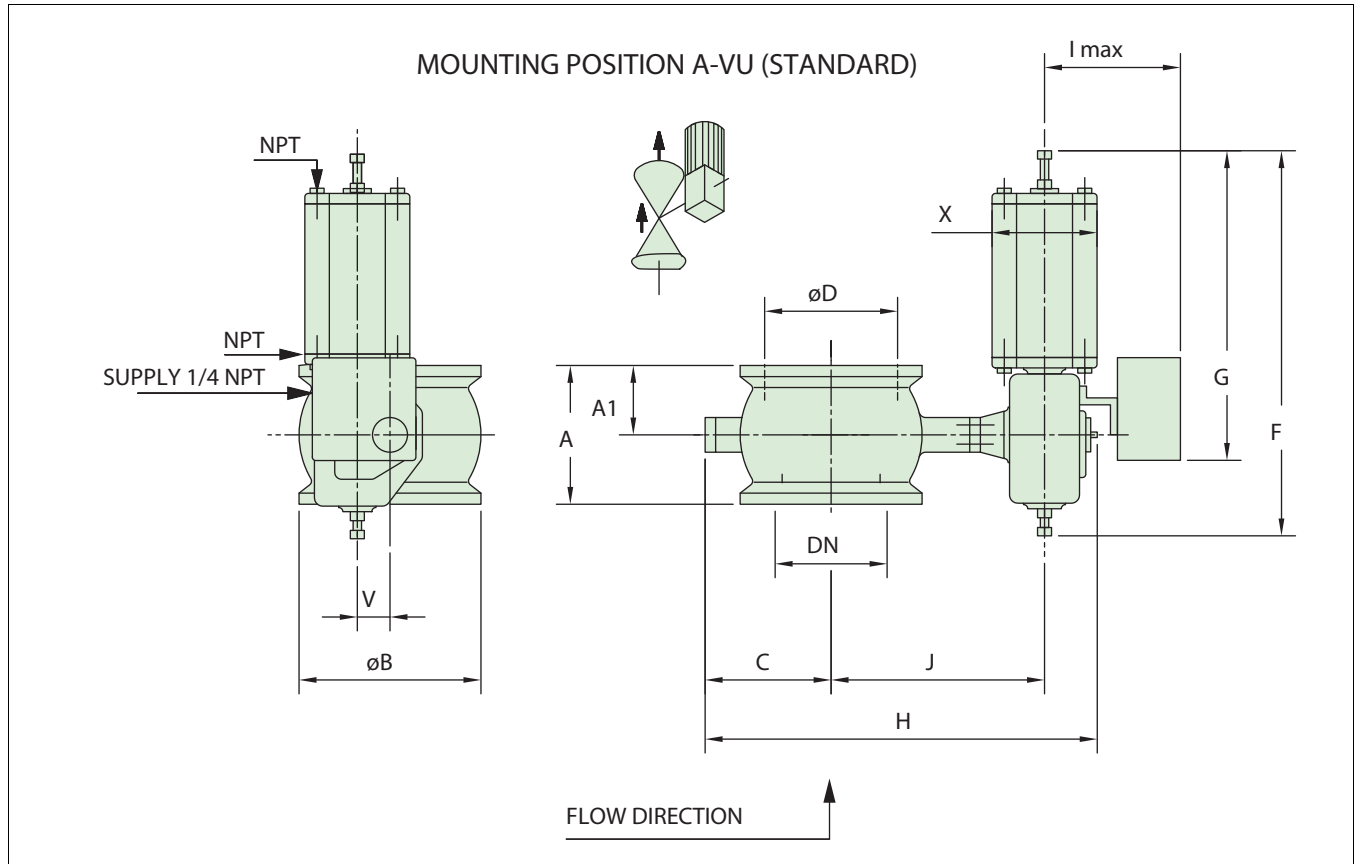

Type	Max. Δp 1)	Dimensions, mm														
		DN	A	A1	ØB	C	ØD	F	G	X	V	J	H	I max	NPT	kg
RA_025-B1J6/B1JA6	50/50	25	50	21	64	56	33	485	368	110	36	167	291	305	3/8	17
RA_040-B1J6/B1JA6	50/50	40	60	21	82	65	49	485	368	110	36	174	306	305	3/8	16
RA_050-B1J6/B1JA6	50/50	50	75	27	100	91	60	485	368	110	36	184	343	305	3/8	17
RA_065-B1J6/B1JA6	50/50	65	100	40	118	97	75	485	368	110	36	194	358	305	3/8	19
RA_080-B1J6/B1JA6	25/50	80	100	38	130	108	89	485	368	110	36	199	374	305	3/8	20
RA_100-B1J6/B1JA6	12/50	100	115	41	158	120	113	485	368	110	36	209	398	305	3/8	23
RA_150-B1J6/B1JA6	-/25	150	160	55	216	174	164	485	368	110	36	257	498	305	3/8	37
RA_025-B1J8/B1JA8	50/50	25	50	21	64	56	33	560	420	135	43	168	293	305	3/8	19
RA_040-B1J8/B1JA8	50/50	40	60	21	82	65	49	560	420	135	43	175	308	305	3/8	20
RA_050-B1J8/B1JA8	50/50	50	75	27	100	91	60	560	420	135	43	185	345	305	3/8	21
RA_065-B1J8/B1JA8	50/50	65	100	40	118	97	75	560	420	135	43	195	360	305	3/8	23
RA_080-B1J8/B1JA8	50/50	80	100	38	130	108	89	560	420	135	43	200	376	305	3/8	24
RA_100-B1J8/B1JA8	50/50	100	115	41	158	120	113	560	420	135	43	210	400	305	3/8	27
RA_150-B1J8/B1JA8	10/25	150	160	55	216	174	164	560	420	135	43	258	500	305	3/8	41
RA_150-B1J10/B1JA10	40/40							650	490	175	51	275	530	225	3/8	55
RA_200-B1J10/B1JA10	15/25	200	200	70	268	201	205	650	490	175	51	310	590	310	3/8	75
RA_200-B1J12/B1JA12	32/35							800	620	215	65	324	635	235	1/2	100
RA_250-B1J16/B1JA16	35/35	250	240	85	324	251	259	990	760	265	78	373	760	340	1/2	170

1) Supply pressure BJ 4 bar / BJA 5 bar

RA - M

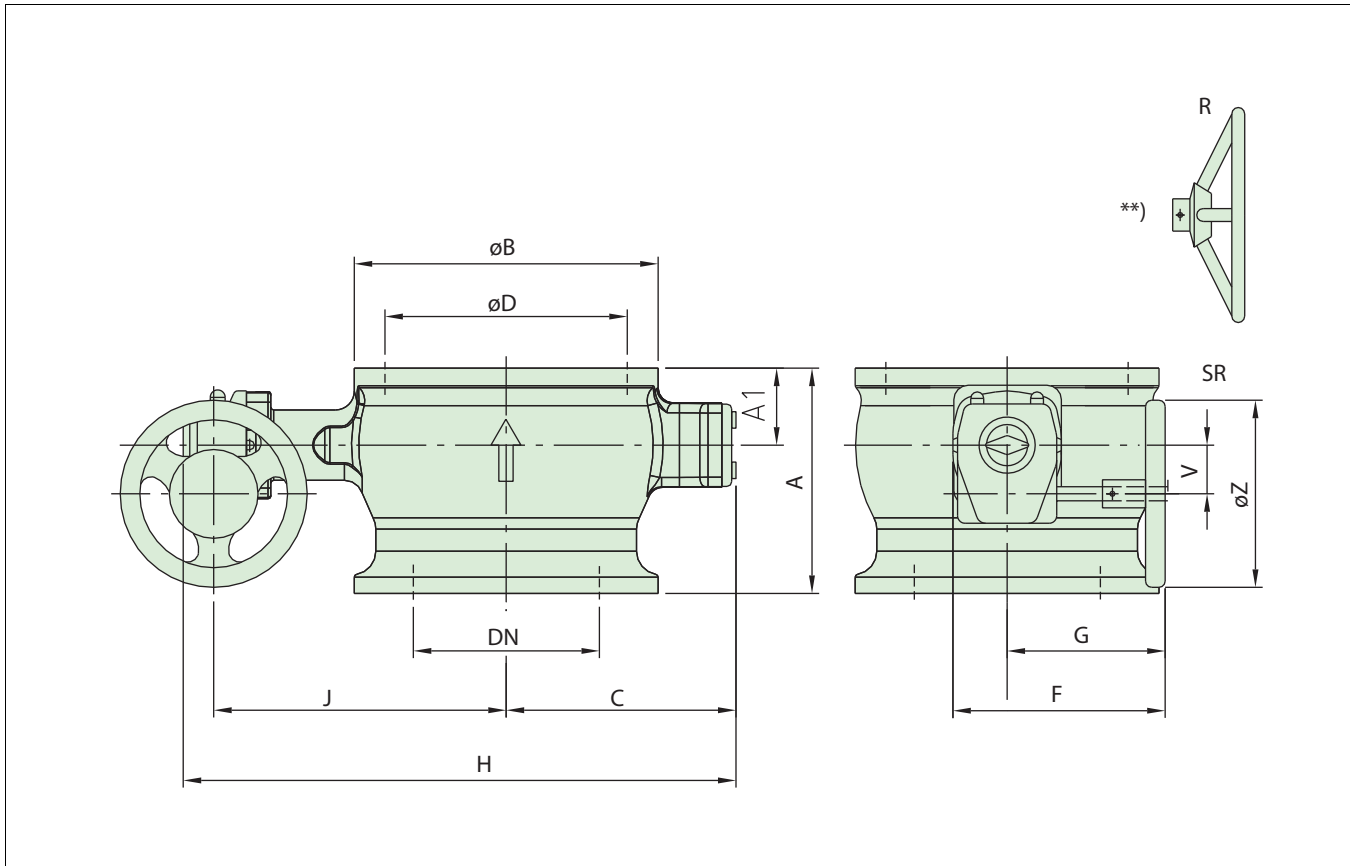

Type	Actuator/ mounting ISO 5211	Dimensions, mm												kg
		DN	ØD	A	A1	ØB	C	F	G	H	J	V	ØZ	
RA	M07/15F05	25	33/38x	50	21	64	56	235	184	223	131	52	160	5.1
	M07/15F05	40	49	60	21	82	65	235	184	238	137	52	160	6.2
	M07/15F05	50	60	75	27	100	91	235	184	275	148	52	160	7.5
	M07/15F05	65	75	100	40	118	97	235	184	288	155	52	160	9.5
	M07/20F07	80	89	100	38	130	108	235	184	315	171	52	160	10
	M07/20F07	100	115	115	41	158	120	235	184	336	180	52	160	14
	M10/25F10	150	164	160	55	216	174	238	187	439	235	52	200	29
	M12/30F12	200	205	200	70	268	201	307	238	524	276	71	315	52
	M12/35F12	250	259	240	82	324	251	307	238	616	318	71	315	78
	M14/35F12	250	259	240	82	324	251	385	285	621	320	86	400	87

***) ACTUATORS M07...M12 ARE EQUIPPED WITH HANDWHEEL TYPE SR,
ACTUATORS M14...M25 ARE EQUIPPED WITH HANDWHEEL TYPE R.

How to order

Example: The following example is for a RA valve, with a standard capacity trim (-), flangeless body design ASME Class 300 (RA), standard keyway (A), size (080), body CF8M,

segment type 329+Hard chromium, screws A2-70, shafts, pins, & bearings AISI 329/PTFE (A) and seat cobalt based alloy, back seal PTFE lip seal (S).

	RA	A	080	A	S
1.	2.	3.	4.	5.	6.

1.	Q-Trim or low-capacity C _v
-	Standard capacity C _v or without a Q-trim.
Q	Q-trim to reduce noise and cavitation.
C005	Max. C _v = 0.5, DN25 valve.
C015	Max. C _v = 1.5, DN25 valve.
C05	Max. C _v = 5, DN25 valve.
C15	Max. C _v = 15, DN25 valve.
2.	Product series / Design
RA	Flangeless, reduced bore, manufacturer face to face length, Body Class 300/PN 40
3.	Construction
A	Standard drive shaft with keyway
4.	Size
	Size in millimeters: 025, 040, 050, 065, 080, 100, 150, 200, 250.

5.	Body	Segment	Screws	Shafts, pins bearings
A	CF8M	Type 329+ Hard chromium	A2-70	AISI 329/ PTFE
S	CF8M	Type 329	A2-70	AISI 329/PTFE
H (with T6 seat)	CW-6M (Hastelloy C)	CW-6M	A2-70	Hastelloy C/ PVDF
U (with U seat)	CK3MCuN (SMO)	ASTM A351 gr. CK3MCuN + ceramic coating (TiO)	A2-70	UNS31254/Filled PTFE on SMO 254 net

6.	Seat
S	Cobalt based alloy, back seal PTFE lip seal.
T	X-treme sizes DN 25 - 150, metal body, back seal PTFE lip seal. PTFE+C25 % sizes DN 200 - 250, metal body, back seal PTFE lip seal.
E	Cobalt based alloy, erosion-resistant version non-tight.
U	Titanium, back seal virgin PTFE lip seal/titanium spring
1S	316 SS + Cobalt based hard facing, 2-way tight metal seat

Valmet Flow Control Oy

Vanha Porvoontie 229, 01380 Vantaa, Finland.

Tel. +358 10 417 5000.

www.valmet.com/flowcontrol

Subject to change without prior notice.

Neles, Neles Easyflow, Jamesbury, Stonel, Valvcon and Flowrox, and certain other trademarks, are either registered trademarks or trademarks of Valmet Oyj or its subsidiaries in the United States and/or in other countries.

For more information www.neles.com/trademarks

