

Neles™ PFA lined ball valve PB1 series

PB1 series PFA lined ball valve is a full bore design to minimize pressure loss and provide maximum flow capacity. The flow port and internal parts are fully covered with PFA for excellent corrosion resistance.

The ISO mounting pad makes it easy for actuator automation.



Technical description

- Sizes DN15 to DN100
- EN1092-1 PN16
- Two-piece body construction
- Bi-directional bubble-tight shut-off

Features

- ISO 5211 mounting pad for direct mounting of handle, gear operator, manual override, or actuator
- Internal entry blow-out proof stem design
- Lockable handle for manual operation
- Liner thickness no less than 2.5 mm
- 15 Kv spark test is 100% done to check liner porosity
- 100% visual inspection on lining parts of each valve to avoid pin holes, porosity, cracks or surface discontinuities

Applications

- Sulfuric acid
- Nitric acid
- Hydrochloric acid
- Phosphoric acid
- Chlorine
- Bromine
- Sea water
- Brine

Exploded view and parts list

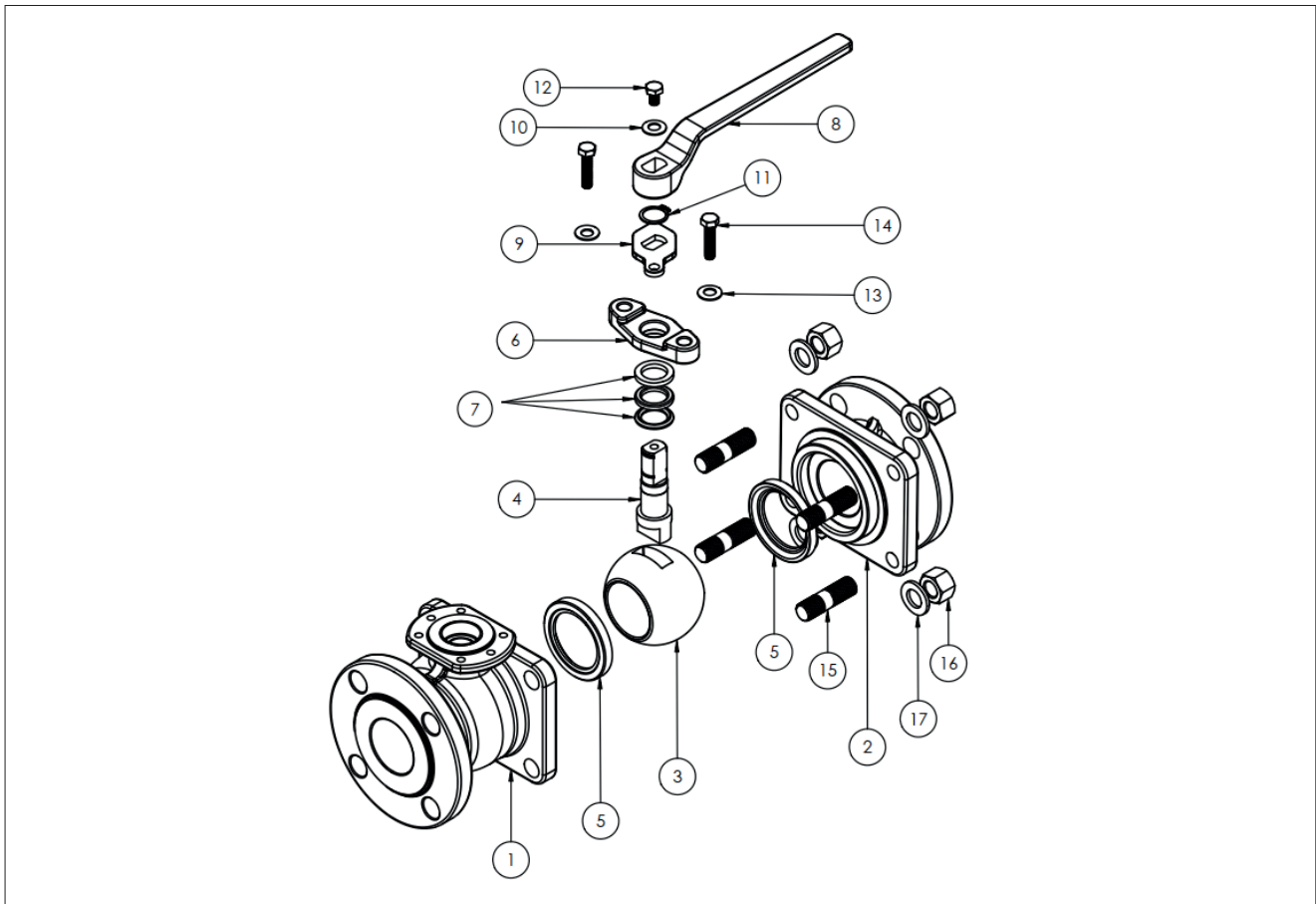

Bill of material and parts list

Part no.	Part name	Material	
		Ductile iron	Stainless steel
		D2	S4
1	Body	EN-JS-1040+PFA	EN 10213-1.4308+PFA
2	Cap	EN-JS-1040+PFA	EN 10213-1.4308+PFA
3	Ball	ASTM A351 CF8+PFA or ASTM A276 304+PFA	
4	Stem	ASTM A276 304+PFA	
5	Seat	TFM 1600	
6	Gland	ASTM A351 CF8	
7	Gland packing	PTFE	
8	Handle	ASTM A216 WCB	ASTM A351 CF8
9	Stop plate	ASTM A276 304	
10	Washer	ASTM A276 304	
11	C-ring	ASTM A276 304	
12	Bolt	ASTM A193 Gr. B8	
13	Washer	ASTM A276 304	
14	Gland bolt	ASTM A193 Gr. B8	
15	Body bolt	ASTM A193 Gr. B8	
16	Body nut	ASTM A194 Gr.8	
17	Washer	ASTM A276 304	

Technical specifications

Nominal diameter:	DN15 – DN100	Face to face length:	EN 558
Pressure rating:	PN 16	Leakage rate:	ISO 5208 Rate A
Flange accommodation:	EN1092-1		

Flow data

The table at right provides flow coefficients for PB1 series valves covered in this bulletin. Cv values represent the flow of water at +600 °F through the valve in US gallons per minute at a pressure drop of 1 psi. The metric equivalent, Kv, is the flow of water at +160 °C through the valve in cubic meters per hour at a pressure drop of 1 kg/cm².

Valve size DN	Cv	Kv
15	19	16
20	45	39
25	88	76
40	257	220
50	425	368
65	783	677
80	1053	902
100	2130	1843

Operating temperature & pressure

Valve ratings, indicated by the solid line in the chart, are based on differential pressure with the valve ball in the fully closed position. The dotted line indicates the temperature where the pressure rating changes. The solid line is the valve rating as established by the body material, seat and seal materials, and lining material. Ductile iron valves are rated to a minimum temperature of -10 °C . Low temperature limit for the TFM seat is -30 °C .

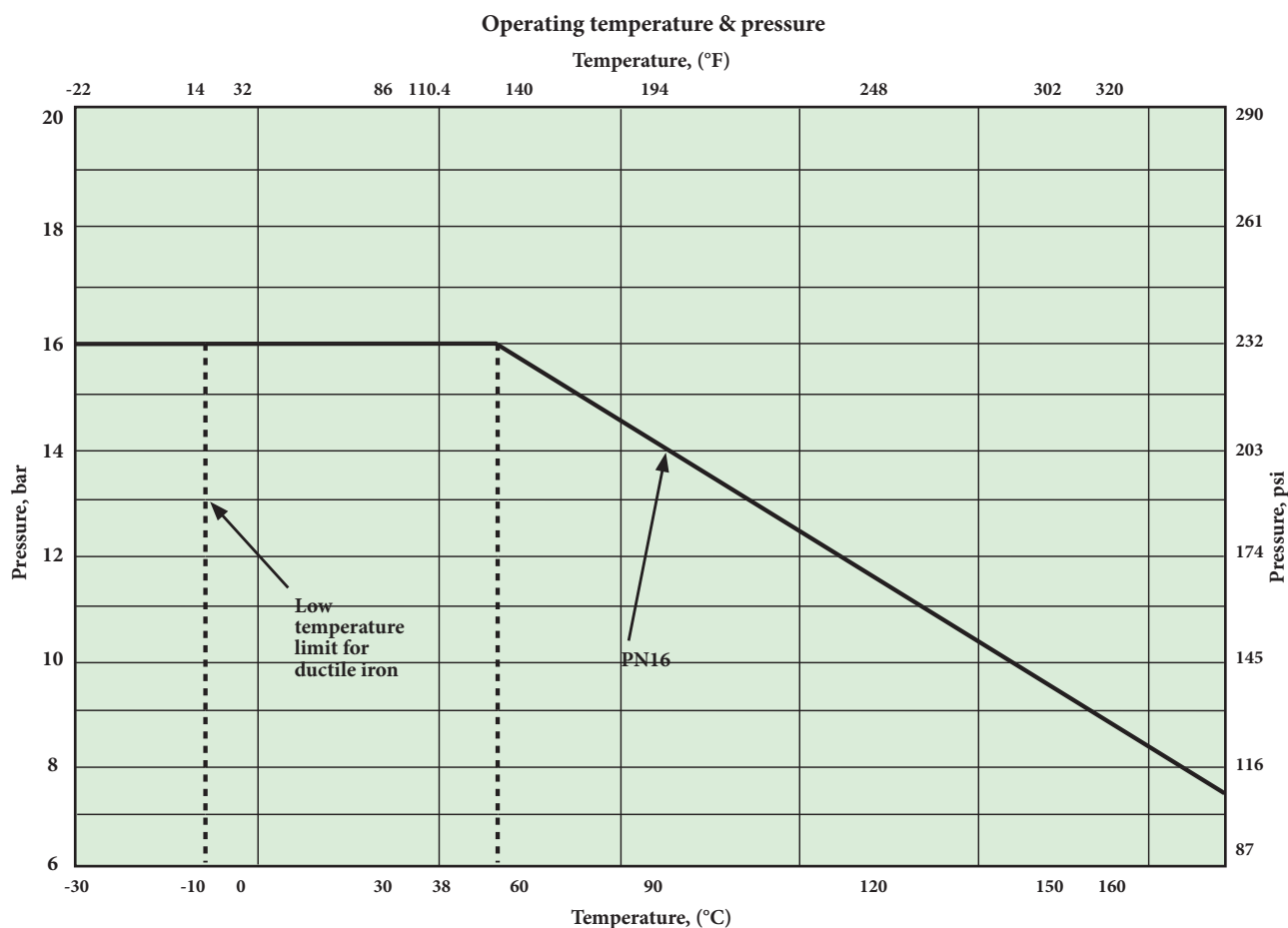

Valve torque data

Use this torque chart as a guide for actuator selection. The recommended minimum actuator torque includes a safety factor and is suitable for the maximum differential pressure of the fluid that the valve can withstand.

Valve size DN	Recommended actuator torque		
	N.m	lb-ft	kgf.cm
15	6	4	56
20	7	6	70
25	8	6	84
40	21	15	210
50	35	25	350
65	48	35	490
80	62	45	630
100	76	56	770

Actuator selection

Selected rack and pinion actuator sizes in the chart are based on 4 barg minimum air supply pressure. Selected spring return actuator size is suitable for fail open or fail close configuration.

Valve size DN	Recommended actuator model 4 bar air supply	
	RNP DN00	RNP SR40
15	RNP 40	RNP 50
20	RNP 40	RNP 50
25	RNP 40	RNP 50
40	RNP 63	RNP 80
50	RNP 63	RNP 90
65	RNP 80	RNP 100
80	RNP 80	RNP 100
100	RNP 90	RNP 110

Dimensions

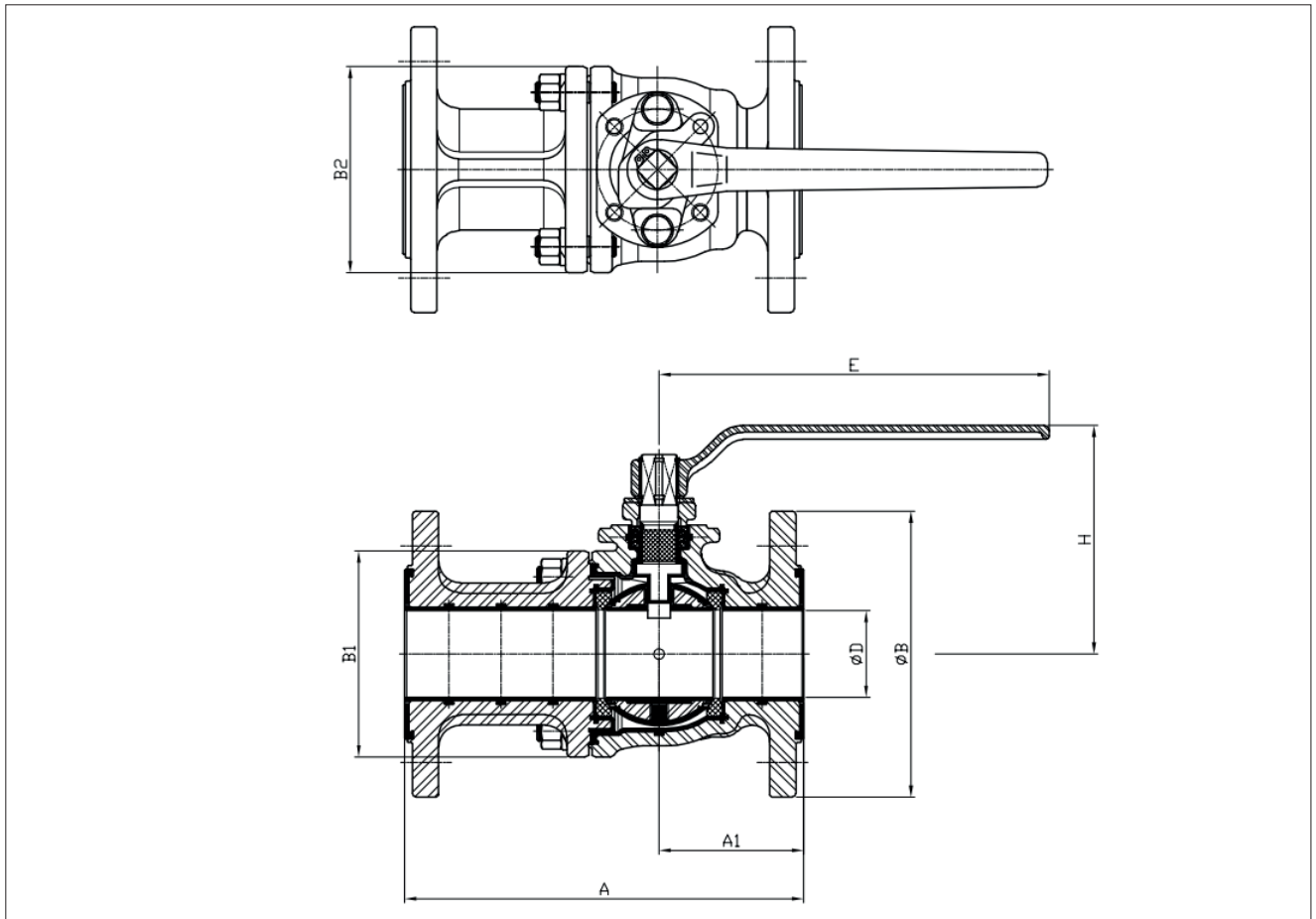

Valve size DN	Dimensions								ISO5211	Weight Kg
	ΦD	A	A1	ΦB	B1	B2	H	E		
15	15	130	46	95	65.8	65.8	81	145	F04	2.7
20	20	150	50.8	105	67.9	67.9	83	145	F04	3.4
25	25	160	61.6	115	85.3	85.3	98	165	F05	4.9
40	40	200	77.5	150	106.4	106.4	124	225	F07	9.1
50	50	230	83.4	165	119.1	119.1	132	225	F07	12
65	65	290	121.8	185	158.5	179	164	350	F07	19
80	80	310	126.1	200	186.2	210	173	350	F07	24.2
100	100	350	149.5	220	228	228	229	400	F10	37.2

How to order

1	2	3	4	5	6	7	8
PB1	K	A	025	D2	Z	V	A

1. sign	Valve series & style
PB1	PFA lined ball valve, full bore, face-to-face: EN-558

2. sign	Pressure rating
K	EN 1092-1 PN 16

3. sign	Construction
A	Standard construction, PFA lining, PED compliance
B	Standard construction, PFA lining, Non PED compliance

4. sign	DN
015	15
020	20
025	25
040	40
050	50
065	65
080	80
100	100

5. sign	Material of body & trim		
	Body	Ball	Stem
S4	1.4308+PFA	304+PFA	304+PFA
D2	JS1040+PFA	304+PFA	304+PFA

6. sign	Material of seat
Z	TFM 1600

7. sign	Packing material
V	PTFE packing, no live loading

8. sign	Version
A	Model A

Valmet Flow Control Oy (part of Valmet)

Vanha Porvoontie 229, 01380 Vantaa, Finland.

Tel. +358 10 417 5000.

www.valmet.com/flowcontrol

Subject to change without prior notice.

Neles, Neles Easyflow, Jamesbury, Stonel, Valvcon and Flowrox, and certain other trademarks, are either registered trademarks or trademarks of Valmet Oyj or its subsidiaries in the United States and/or in other countries.

For more information www.neles.com/trademarks

