

Intelligent valve controller

Neles™ ND7000

Neles ND7000 is a digital valve controller designed to operate on all control valve actuators and in all industry areas. ND7000 is a reliable and future-proof investment with life-time support

Key features

- Benchmark control performance on rotary and linear valves
- Reliable and robust design
- The rugged cover protects the unit from environmental hazards and external abuse
- Easy commissioning and operation
- Safety; IEC 61508 compliant up to and including SIL 2 by TUV
- Language selection: English, German and French
- Local / remote operation
- Remote mounting (option)
- Basic device diagnostics including
 - Self-diagnostics
 - Deviation trend
 - Counters
 - Extended off-line tests

Total cost of ownership

- Low energy and air consumption
- Future proof design allows further options at a reduced cost
- Retro-fit to existing installations (Neles or 3rd party valves)

Minimized process variability

- Linearisation of the valve flow characteristics
- Excellent dynamic and static control performance
- Fast response to control signal change
- Accurate internal measurements

Easy installation and configuration

- Same device can be used for linear and rotary valves, double and single-acting actuators
- Simple fast calibration and configuration
 - using Local User Interface (LUI)
 - using DTM / EDD in a remote location
 - using Distributed Control System (DCS) asset management tools
- Low power consumption enables installation to all common control systems



Open solution

- Valmet is committed to delivering products that freely interface with software and hardware from a variety of manufacturers; ND7000 is no exception. This open architecture allows the ND7000 to be integrated with other field devices to give an unprecedented level of controllability.
- FDT and EDD based multi-vendor support configuration
- Support files for ND7000 are available from our internet page, www.neles.com/ND7000

ND7000 mounting on actuators and valves

- Mounted on single and double acting actuators
- Both rotary and linear valves
- Ability to attach options to electronics and mechanics later
- 1-point calibration feature enables mounting without disturbing the process

Product reliability

- Designed to operate in harsh environmental conditions
- Rugged modular design
- Excellent temperature characteristics
- Vibration and impact tolerant
- IP66 enclosure
- Protected against humidity
- Maintenance free operation
- Resistant to dirty air
- Wear resistant and sealed components
- Contact less position measurement

Technical description

The ND7000 is a 4–20 mA powered microcontroller-based digital valve controller. The device contains a Local User Interface (LUI) enabling local configuration.

The powerful 32-bit microcontroller controls the valve position.

The measurements include:

- Input signal
- Valve position with contactless sensor
- Actuator pressures, 2 independent measurements
- Supply pressure
- Spool valve position
- Device temperature

Self-diagnostics guarantees that all measurements operate correctly. After connections of electric signal and pneumatic supply the micro controller (μC) reads the input signal, position sensor (α), pressure sensors (P_s , P_1 , P_2) and spool position sensor (SPS). A difference between input signal and position sensor (α) measurement is detected by control algorithm inside the μC . The μC calculates a new value for prestage (PR) coil current based on the information from the input signal and from the sensors. The changed current to the PR changes the pilot pressure to the spool valve. Reduced pilot pressure moves the spool and the actuator pressures change accordingly. The spool opens the flow to the driving side of the double diaphragm actuator and opens the flow out from the other side of the actuator. The increasing pressure will move the diaphragm piston. The actuator and feedback shaft rotate. The position sensor (α) measures the rotation for the μC . The μC using control algorithm modulates the PR-current from the steady state value until the new position of the actuator, according to the input signal, is reached.

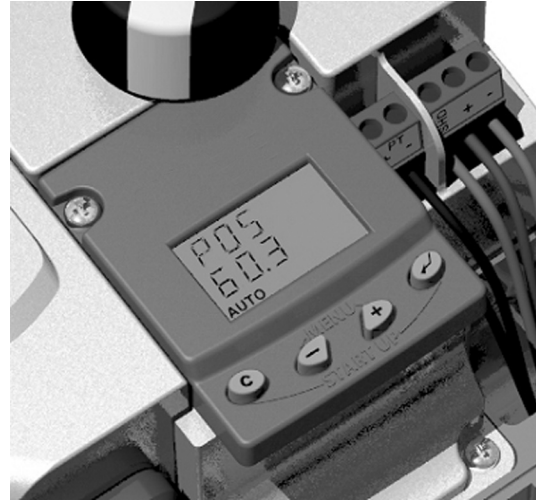
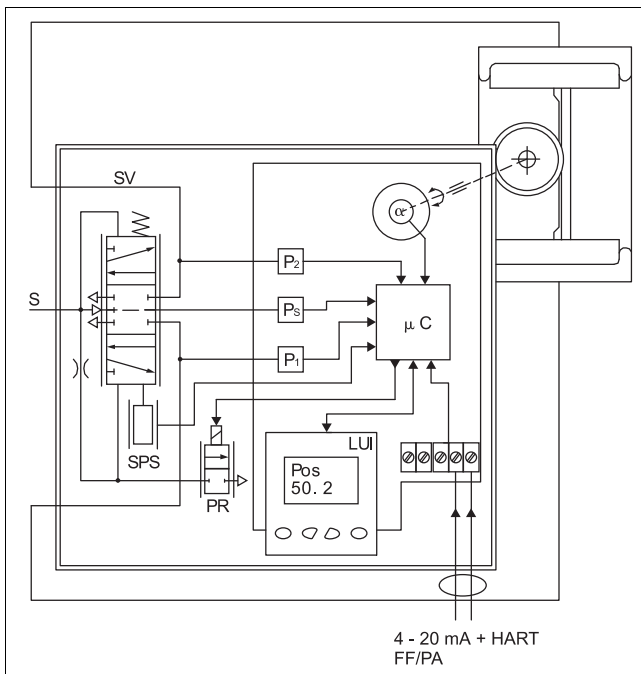

Fig. 1 Local User Interface (LUI) enables real time awareness of control parameters in the device at a glance.

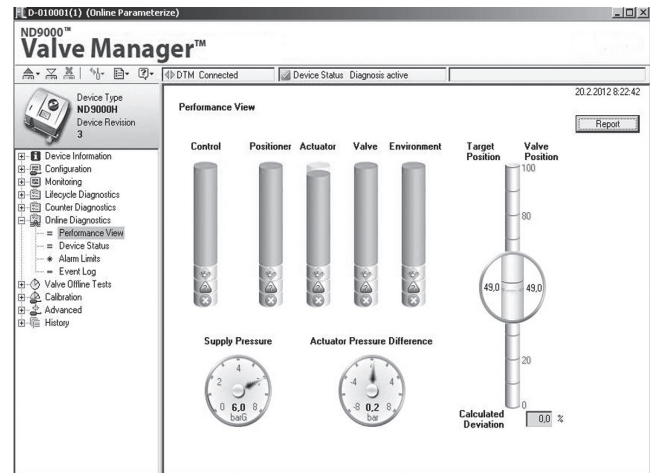

Fig. 2 ND7000 diagnostics includes four Offline Tests. The test results can be compared with earlier tests.

Technical specifications

ND7000 digital valve controller

General

Loop powered, no external power supply required.
 Suitable for rotary and linear valves.
 Actuator connections in accordance with VDI/VDE 3845 and IEC 60534-6 standards.
 Action: Double or single acting
 Travel range: Linear; 10–120 mm / 0.4–4.7 in rotary;
 45–95 degrees. Measurement range
 110° with freely rotating feedback shaft

Environmental influence

Standard temperature range:
 -40 °C to +85 °C / -40 °F to +185 °F
 Influence of temperature on valve position:
 0.5 % / 10 °K
 Influence of vibration on valve position:
 < 1 % under 2g 5–150 Hz,
 1g 150–300 Hz, 0.5g 300–2000 Hz

Enclosure

Material: ND7100: Anodised aluminum alloy and polymer composite
 ND7200: Anodised aluminum alloy and tempered glass
 Protection class: IP66, Nema 4x
 Pneumatic ports: G 1/4 (ND7100)
 1/4 NPT (ND7200)
 Cable gland thread: M20x1.5 (ND7000)
 Weight: 1.8 kg / 4.0 lbs (ND7100)
 3.4 kg / 7.5 lbs (ND7200)
 Mechanical and digital position indicator visible through main cover.

Pneumatics

Supply pressure: 1.4–8 bar / 20–115 psi
 Effect of supply pressure on valve position:
 < 0.1 % at 10 % difference in inlet pressure
 Air quality: Acc. to ISO 8573-1
 Solid particles: Class 5 (3 – 5 µm filtration is recommended)
 Humidity: Class 1 (dew point 10 °C / 50 °F below minimum temperature is recommended)
 Oil class: 3 (or < 1 ppm)
 Capacity with 4 bar / 60 psi supply:
 5.5 Nm³/h / 3.3 scfm (spool valve 2)
 12 Nm³/h / 7.1 scfm (spool valve 3)
 38 Nm³/h / 22.4 scfm (spool valve 6)
 Consumption with 4 bar / 60 psi supply in steady state position:
 <0.6 Nm³/h / 0.35 scfm
 (spool valve 2 & 3)
 <1.0 Nm³/h / 0.6 scfm (spool valve 6)

Electronics

HART

Supply power: Loop powered, 4–20 mA
 Minimum signal: 3.6 mA
 Current max : 120 mA
 Load voltage: up to 9.7 VDC/20 mA
 (corresponding 485 Ω)
 Voltage: max. 30 VDC
 Polarity protection: -30 VDC
 Over current protection: active over 35 mA

Performance with moderate constant-load actuators

Dead band: ≤0.1 %
 Hysteresis: <0.5 %

Local User Interface (LUI) functions

- Local control of the valve
- Monitoring of valve position, target position, input signal, temperature, supply and actuator pressure difference
- Guided-startup function
- LUI may be locked remotely to prevent unauthorized access
- Calibration: Automatic / Manual, manual linearization, 1-point calibration
- Control configuration: aggressive, fast, optimum, stable, maximum stability
- Configuration of the control valve
 - Rotation: valve rotation clockwise or counter-clockwise to close
 - Dead Angle
 - Low cut-off, cut-off safety range (default 2 %)
 - Positioner fail action, open/close
 - Signal direction: Direct/reverse acting
 - Actuator type, double/single acting
 - Valve type, rotary/linear
 - Language selection: English, German and French

Position transmitter (optional)

Output signal: 4–20 mA
 (galvanic isolation; 600 VDC)
 Supply voltage: 12–30 VDC
 Resolution: 16 bit / 0.244 µA
 Linearity: <0.05 % FS
 Temperature effect: <0.35 % FS
 External load: max 0–780 Ω
 max 0–690 Ω for intrinsically safe

Approvals and electrical values, HART

| Certificate | Approval | Electrical values |
|--|--|---|
| ATEX | | |
| ND_X VTT 09 ATEX 033X VTT 09 ATEX 034X EN 60079-0: 2009/2012 EN 60079-11: 2012 EN 60079-26: 2007 EN 60079-31: 2008 EN 60079-0: 2009/2012 EN 60079-11: 2012 EN 60079-15: 2010 EN 60079-31: 2008 | II 1G Ex ia IIC T6...T4 Ga II 1D Ex ta IIIC T90 °C Da II 2 G Ex ib IIC T6...T4 Gb II 2 D Ex tb IIIC T90 °C Db II 1G Ex ia IIC T6...T4 Ga II 3 G Ex nA IIC T6...T4 Gc II 3 D Ex tc IIIC T90 °C Dc II 3 G Ex ic IIC T6...T4 Gc II 3 D Ex tc IIIC T90 °C Dc | Input: $U_i \leq 28$ V, $I_i \leq 120$ mA, $P_i \leq 1$ W, $C_i \leq 13.5$ nF, $L_i \leq 53$ μ H. Output: $U_i \leq 28$ V, $I_i \leq 120$ mA, $P_i \leq 1$ W, $C_i \leq 13.5$ nF, $L_i \leq 53$ μ H Input: $U_i \leq 30$ V, $I_i \leq 152$ mA Output: $U_i \leq 30$ V, $I_i \leq 152$ mA Input: $U_i \leq 30$ V, $I_i \leq 152$ mA, P_{max} = device limits itself, $C_i \leq 13.5$ nF, $L_i \leq 53$ μ H. Output: $U_i \leq 30$ V, $I_i \leq 152$ mA, P_{max} = device limits itself, $C_i \leq 13.5$ nF, $L_i \leq 53$ μ H |
| ND_E1 SIRA 11 ATEX 1006X EN 60079-0:2009 EN 60079-1:2007 EN 60079-31:2009 | II 2 G Ex d IIC T6...T4 Gb II 2 D Ex tb IIIC T80 °C...T105 °C Db | Input: $U_i \leq 30$ V Output: $U_i \leq 30$ V, P_{max} = device limits itself |
| IECEX | | |
| ND_X IECEX VTT 10.0004X IECEX VTT 10.0005X IEC 60079-0: 2007/2011 IEC 60079-11: 2011 IEC 60079-26: 2006 IEC 60079-31: 2008 IEC 60079-0: 2007/2011 IEC 60079-11: 2011 IEC 60079-15: 2010, IEC 60079-31: 2008 | Ex ia IIC T6...T4 Ga Ex ta IIIC T90 °C Da Ex ib IIC T6...T4 Gb Ex tb IIIC T90 °C Db Ex nA IIC T6...T4 Gc Ex tc IIIC T90 °C Dc Ex ic IIC T6...T4 Gc Ex tc IIIC T90 °C Dc | Input: $U_i \leq 28$ V, $I_i \leq 120$ mA, $P_i \leq 1$ W, $C_i \leq 13.5$ nF, $L_i \leq 53$ μ H Output: $U_i \leq 28$ V, $I_i \leq 120$ mA, $P_i \leq 1$ W, $C_i \leq 13.5$ nF, $L_i \leq 53$ μ H Input: $U_i \leq 30$ V, $I_i \leq 152$ mA Output: $U_i \leq 30$ V, $I_i \leq 152$ mA Input: $U_i \leq 30$ V, $I_i \leq 152$ mA, P_{max} = device limits itself, $C_i \leq 13.5$ nF, $L_i \leq 53$ μ H Output: $U_i \leq 30$ V, $I_i \leq 152$ mA, P_{max} = device limits itself, $C_i \leq 13.5$ nF, $L_i \leq 53$ μ H |
| ND_E1 IECEX SIR 11.0001X IEC 60079-0:2011 IEC 60079-1:2007 IEC 60079-31:2008 | Ex d IIC T6...T4 Gb Ex tb IIIC T80 °C...T105 °C Db | Input: $U_i \leq 30$ V Output: $U_i \leq 30$ V, P_{max} = device limits itself |
| INMETRO | | |
| ND_Z NCC 12.0793 X NCC 12.0794 X ABNT NBR IEC 60079-0:2008 (2011) ABNT NBR IEC 60079-11:2009 ABNT NBR IEC 60079-26:2008 (2009) ABNT NBR IEC 60079-27:2010 ABNT NBR IEC 60079-0:2008 (2011) ABNT NBR IEC 60079-11:2009 IEC 60079-15:2010 ABNT NBR IEC 60079-27:2010 ABNT NBR IEC 60529:2009 | Ex ia IIC T4/T5/T6 Ga Ex ia IIC T4/T5/T6 Gb Ex nA IIC T4/T5/T6 Gc Ex ic IIC T4/T5/T6 Gc | Input: $U_i \leq 28$ V, $I_i \leq 120$ mA, $P_i \leq 1$ W, $C_i \leq 22$ nF, $L_i \leq 53$ μ H Output: $U_i \leq 28$ V, $I_i \leq 120$ mA, $P_i \leq 1$ W, $C_i \leq 22$ nF, $L_i \leq 53$ μ H Input: $U_i \leq 30$ V, $I_i \leq 152$ mA Output: $U_i \leq 30$ V, $I_i \leq 152$ mA Input: $U_i \leq 30$ V, $I_i \leq 152$ mA, P_{max} = device limits itself, $C_i \leq 22$ nF, $L_i \leq 53$ μ H. Output: $U_i \leq 30$ V, $I_i \leq 152$ mA, P_{max} = device limits itself, $C_i \leq 22$ nF, $L_i \leq 53$ μ H |
| ND_E5 NCC 12.0795 X ABNT NBR IEC 60079-0:2008 (2011) ABNT NBR IEC 60079-1:2009 (2011) ABNT NBR IEC 60079-31:2011 ABNT NBR IEC 60529:2009 | Ex d IIC T4/T5/T6 Gb Ex tb IIIC T100 °C Db IP66 | Input: $U_i \leq 30$ V Output: $U_i \leq 30$ V, P_{max} = device limits itself |

Dimensions

ND7100

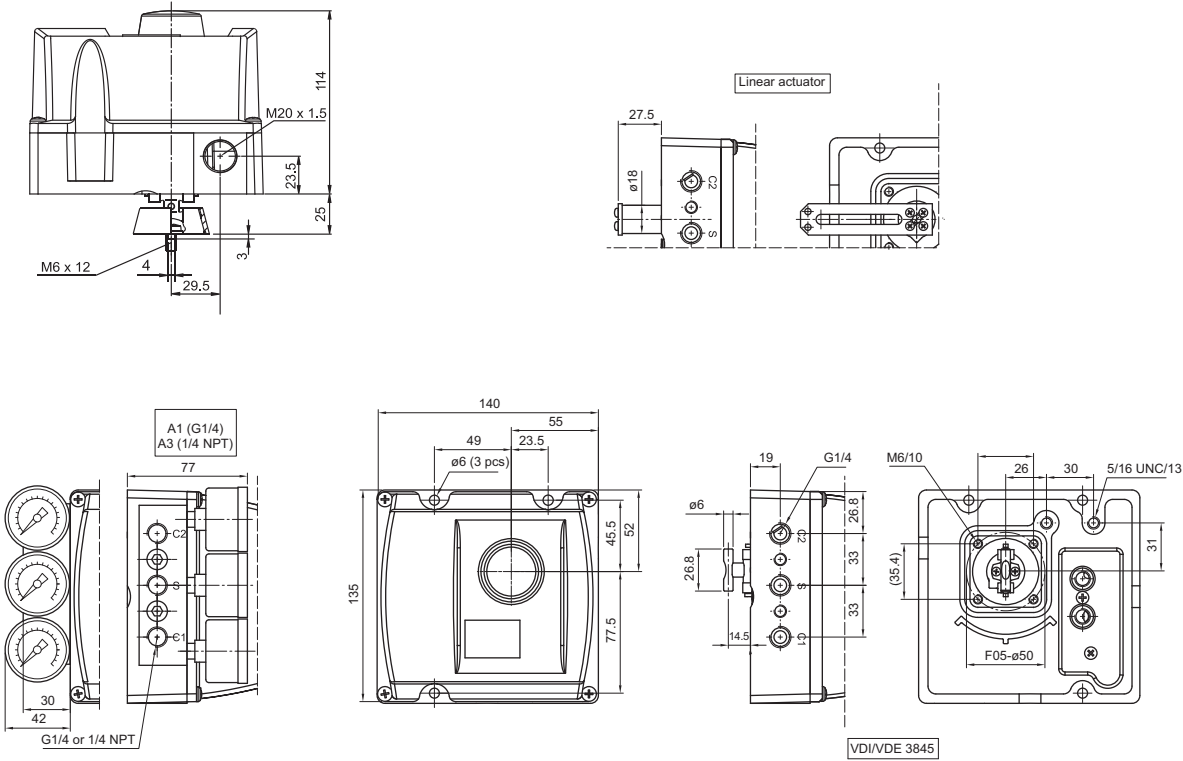

ND7200

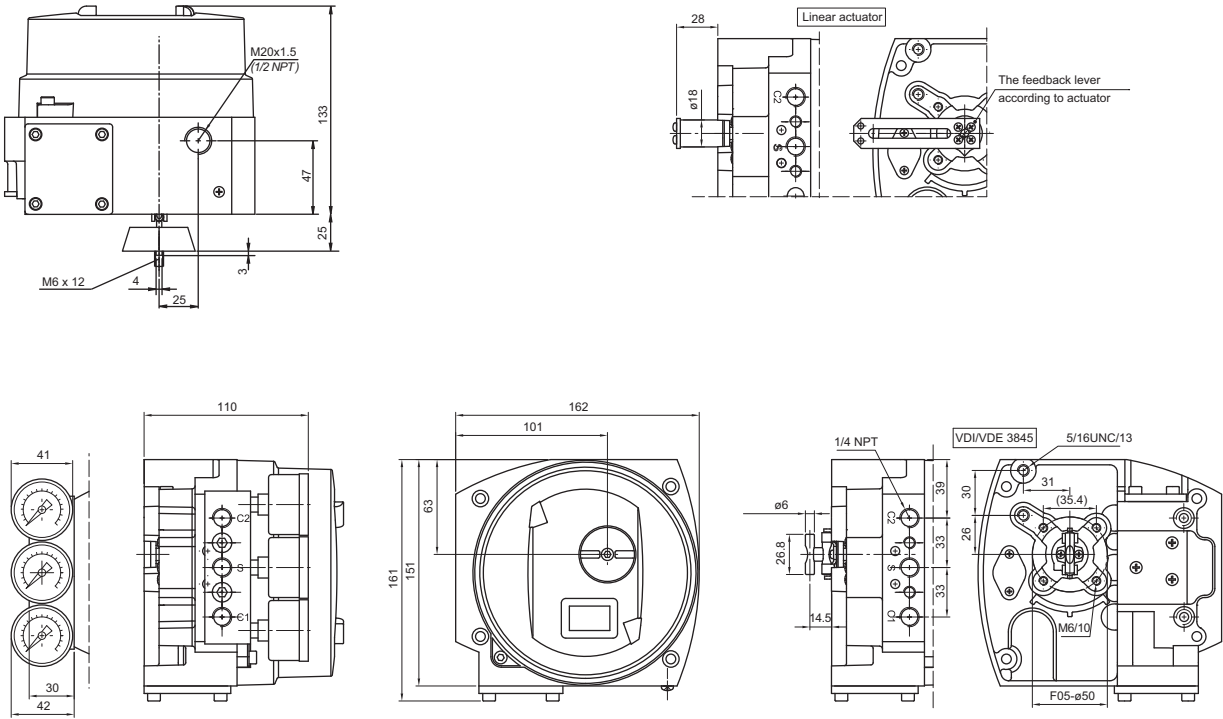

How to order

Digital valve controller ND7000

| 1. | 2. | 3. | 4. | 5. | 6. | 7. | 8. | 9. |
|----|----|----|----|----|----|----|----|-----|
| ND | 7 | 1 | 03 | H | x | T | / | 102 |

| 1. | PRODUCT GROUP |
|----|---------------------------|
| ND | Digital valve controller. |

| 2. | SERIES CODE |
|----|--|
| 7 | Series 7000 digital valve controller with universal shaft and attachment face according to standard VDI/VDE 3845. Relevant shaft adapter included in mounting kits. When valve positioners are separate deliveries, shaft adapter kit is supplied. |

| 3. | ENCLOSURE |
|----|---|
| 1 | Standard IP66 / NEMA 4X enclosure. |
| 2 | Flameproof (Ex d) IP66 / NEMA 4X enclosure. |

| 4. | SPOOL VALVE | PNEUMATIC CONNECTIONS (S, C1, C2) |
|----|--|--------------------------------------|
| 02 | Low capacity. Stroke volume of actuator < 1 dm ³ . | G 1/4 (ND7100), 1/4 NPT (ND7200). |
| 03 | Medium capacity. Stroke volume of actuator 1–3 dm ³ . | G 1/4 (ND7100), 1/4 NPT (ND7200). |
| 06 | High capacity. Stroke volume of actuator > 3 dm ³ . | G 1/4 (ND7100), 1/4 NPT (ND7200). |

| 5. | COMMUNICATION / INPUT SIGNAL RANGE |
|----|---|
| H | 4–20 mA, HART communication. Will be delivered as HART 6, can be changed to HART 7 from LUI. Supply voltage 30 V DC. Load voltage: up to 9.7 V DC at 20 mA corresponding to 485 Ω (maximum voltage drop). |

| 6. | APPROVALS FOR HAZARDOUS AREAS |
|----|---|
| N | No approvals for hazardous areas. M20 x1.5 conduit entry. Temperature range -40 °C to +85 °C. |
| N7 | N7 No approvals for hazardous areas. Like N, but this is with Russian language machine plate. |

| | |
|---|---|
| X | ATEX and IECEx certifications: II 1 G Ex ia IIC T6...T4 Ga II 1 D Ex ta IIIC T90 °C Da II 2 G Ex ib IIC T6...T4 Gb II 2 D Ex tb IIIC T90 °C Db Temperature range: T4: -40 °C to +80 °C; T5: < +65 °C; T6: < +50 °C. |
| | II 3 G Ex nA IIC T6...T4 Gc II 3 D Ex tc IIIC T90 °C Dc II 3 G Ex ic IIC T6...T4 Gc II 3 D Ex tc IIIC T90 °C Dc Temperature range: T4: -40 °C to +85 °C; T5: < +75 °C; T6: < +60 °C. |

| | |
|----|---|
| X7 | M20 x 1.5 conduit entry. TR CU (Russian) certification: 0Ex ia IIC T6...T4 Ga X / Ex ia IIIC T95 °C...T125 °C Da X 0Ex ia IIC T6...T4 Ga X / Ex ta IIIC T95 °C...T125 °C Da X 1Ex ib IIC T6...T4 Gb X / Ex ib IIIC T95 °C...T125 °C Db X 1Ex ib IIC T6...T4 Gb X / Ex tb IIIC T95 °C...T125 °C Db X 2Ex nA IIC T6...T4 Gc X / Ex ic IIIC T95 °C...T125 °C Dc X 2Ex nA IIC T6...T4 Gc X / Ex tc IIIC T95 °C...T125 °C Dc X 2Ex ic IIC T6...T4 Gc X / Ex ic IIIC T95 °C...T125 °C Dc X 2Ex ic IIC T6...T4 Gc X / Ex tc IIIC T95 °C...T125 °C Dc X Temperature range: Ta according to separate table (see certificate). Available without limit switches or with certified inductive limit switches |
| | CCC (Chinese) certification: Ex ia IIC T4...T6 Ga Ex ib IIC T4...T6 Gb Ex ic IIC T4...T6 Gc T4: -40°C to +80°C; T5: -40°C to +65°C; T6: -40°C to +50°C |

| | |
|----|---|
| X8 | INMETRO certifications: Ex ia IIC T4/T5/T6 Ga Ex ia IIC T4/T5/T6 Gb Ex nA IIC T4/T5/T6 Gc Ex ic IIC T4/T5/T6 Gc M20 x 1.5 conduit entry. |
| | ATEX and IECEx certifications: II 2 G Ex d IIC T6...T4 Gb II 2 D Ex tb IIIC T80 °C...T105 °C Db Temperature range: T4: -40 °C to +85 °C; T5: < +75 °C; T6: < +60 °C. Not applicable to 3. sign "1". M20 x 1.5 conduit entry. |

| | |
|---|---|
| Z | ATEX and IECEx certifications: II 2 G Ex d IIC T6...T4 Gb II 2 D Ex tb IIIC T80 °C...T105 °C Db Temperature range: T4: -40 °C to +85 °C; T5: < +75 °C; T6: < +60 °C. Not applicable to 3. sign "1". M20 x 1.5 conduit entry. |
| | ATEX and IECEx certifications: II 2 G Ex d IIC T6...T4 Gb II 2 D Ex tb IIIC T80 °C...T105 °C Db Temperature range: T4: -40 °C to +85 °C; T5: < +75 °C; T6: < +60 °C. Not applicable to 3. sign "1". M20 x 1.5 conduit entry. |

| 6. | APPROVALS FOR HAZARDOUS AREAS |
|----|---|
| E4 | Japanese Ex-d Certification: II 2G Ex d IIC T6 Gb II 2D Ex tb IIIC T80 °C Db Temperature range: T6: < +60 °C. Not applicable to 3. sign "1" or "4". |
| E5 | INMETRO certifications: Ex d IIC T4/T5/T6 Gb Ex tb IIIC T100 °C Db IP66 Temperature range: T4: -40 °C to +85 °C; T5: < +75 °C; T6: < +60 °C. Not applicable to 3. sign "1" M20 x 1.5 conduit entry. |
| E7 | TR CU (Russian) certification: IEx d IIC T6...T4 Gb X / Ex tb IIIC T80°C...T105°C Db X Temperature range: Ta according to separate table (see certificate). Available with or without limit switches. |
| E8 | CCC (Chinese) certification: Ex d IIC T4–T6 Gb Ex tD A21 IP66 T80 °C/T95 °C/T105 °C Available with or without limit switches. |

| 7. | OPTIONS OF VALVE CONTROLLER |
|----|-----------------------------|
|----|-----------------------------|

| | |
|---|---|
| T | Internal 2-wire (passive) position transmitter. Analog position feedback signal, output 4–20 mA, supply voltage 12–30 V DC, external load resistance 0–780 Ω. ND7_HXT, ND7_HZT: II 1 G Ex ia IIC T6...T4 Ga II 1 D Ex ta IIIC T90 °C Da II 2 G Ex ib IIC T6...T4 Gb II 2 D Ex tb IIIC T90 °C Db Ui ≤ 28 V, Ii ≤ 120 mA, Pi ≤ 1 W, Ci ≤ 13.5 nF, Li ≤ 53 μH, external load resistance 0–690 Ω. |
| | ND7_HXT, ND7_HZT: II 3 G Ex nA IIC T6...T4 Gc II 3 D Ex tc IIIC T90 °C Dc Ui ≤ 30 V, Ii ≤ 152 mA, Pmax = device limits itself, Ci ≤ 13.5 nF, Li ≤ 53 μH, external load resistance 0–780 Ω. |
| R | Remote mounting Applicable only to 3. sign "1" Requires always external position measurement. For rotary actuator see accessories type code. Output values for: HART Uo(Voc) = 3.53V, Io(Isc) = 12.6mA, Po = 11.1 mW, Co(Ca) = 10nF, Lo(La) = 10μH. |
| C | Arctic temperature option. Temperature range -53 °C to +85 °C / -64 °F to +185 °F Applicable to 3. sign "2 and 3" Applicable to 6. sign "X", "X7", "X8", "E1", "E7" and "E8". Not applicable to 7. sign J (External junction box) Note, Limit switch may limit the temperature range |

| 8. | LIMIT SWITCH TYPE |
|----|-------------------|
|----|-------------------|

| | |
|-----|--|
| I02 | Inductive proximity switches, 2 pcs. IP66 / NEMA 4X enclosure. M20 x 1.5 conduit entry (2 pcs.). Option E2: 1/2 NPT conduit entry (2 pcs.). |
| | P+F; NJ2-12GK-SN, 2-wire type, DC; > 3 mA; < 1 mA, NAMUR NC. Temperature range: -40 °C to +85 °C / -40 °F to +185 °F. Not applicable to 6. sign "E4". Usable up to SIL3 acc. to IEC61508 NOTE: In safety-related applications the sensor must be operated with a qualified fail safe interface, such as P+F KFD2-SH-EX1. |
| I41 | P+F; NJ4-12GK-SN, 2-wire, DC; > 3 mA; < 1 mA, NAMUR NC Temperature range -50 °C to +85 °C / -58 °F to +185 °F) Applicable to 6. sign "N", "X", "X7", "X8", "U", "E1", "E2", "E7" or "E8". Note that device may limit temperature range. |
| K05 | Omron D2VW-5, 3 A - 250 V AC, 0.4 A - 125 V DC, 5 A - 30 V DC. Temperature range: -40 °C to +85 °C / -40 °F to +185 °F. Not applicable to 6. sign "X", "X7", "X8", "Z", "U" and "E4". |

Additional accessories

| FILTER REGULATOR | |
|------------------|--|
| KS | Filter regulator for supply air. Filter size 5 µm. Pressure gauge, scale bar/psi/kPa and kg/cm ² , basic material brass, nickel plated, housing stainless steel, glycerine filled. Temperature range -40 °C to +82 °C / -40 °F to +180 °F. KS option includes a thread nipple 1/4"NPT to 1/4"NPT between filter regulator and positioner which is suitable with ND7200 positioner options A3 and A5 (1/4NPT AIR CONNECTION). Supply air connector in the filter regulator is female 1/4". |
| K1S | Filter regulator for supply air. Filter size 5 µm. Pressure gauge, scale bar/psi/kPa and kg/cm ² , basic material brass, nickel plated, housing stainless steel, glycerine filled. Temperature range -40 °C to +82 °C / -40 °F to +180 °F. K1S option includes a thread nipple 1/4"NPT to G1/4" between filter regulator and positioner which is suitable with ND7100 positioner and with option A1 (G1/4 AIR CONNECTION). Supply air connector in the filter regulator is female 1/4". |

| CONDUIT ENTRY NIPPLES | |
|-----------------------|---|
| CE07 | 1/2 NPT conduit entry nipples M20x1,5 / 1/2 NPT (ND7100) |
| CE08 | R1/2 (PF1/2) conduit entry nipples M20x1,5 / R1/2 (ND7100) |
| CE09 | 1/2 NPT conduit entry nipples Brass M20x1,5 / 1/2 NPT, Exd approved (ND7200) |

| CABLE GLANDS | |
|--|---|
| Not to be used together with conduit entry nipples (CE_) or connection plugs (P_). | |
| CG5 | M20x1.5 grey/plastic, IP66 |
| CG6 | M20x1.5 blue/plastic, IP66, Ex e |
| CG43 | Conduit entry and cable entry adapter for ND7200 M20 (M) x 1/2 NPT (F) S5316 ExdIIC ExdbIIC Gb, IP66 |
| CG44 | Conduit entry and cable entry adapter for ND7200 M20 (M) x G1/2 (F) S5316 ExdIIC ExdbIIC Gb, IP66 |

| PRESSURE GAUGES AND CONNECTION BLOCKS | |
|---------------------------------------|---|
| A1 | Pressure gauges, scale bar/psi/kPa and kg/cm ² , basic material brass, nickel plated, housing stainless steel, glycerine filled. Temperature range -40 °C to +85 °C / -40 °F to +185 °F. Pneumatic connection block, material AlMgSi1, anodized grey. Connections G1/4 (S, C1, C2). |
| A1B | As A1 but includes two pressure gauges with connections G1/4 (S, C2). Use with in single acting use only. |
| A3 | Pressure gauges, scale bar/psi/kPa and kg/cm ² , basic material brass, nickel plated, housing stainless steel, glycerine filled. Temperature range -40 °C to +85 °C / -40 °F to +185 °F. Pneumatic connection block, material AlMgSi1, anodized grey. Connections 1/4 NPT (S, C1, C2), converts also ND71_ connections to 1/4 NPT. |
| A3B | As A3 but two pressure gauges with connections 1/4 NPT (S, C2). Converts also ND71_ connections to 1/4 NPT. Use with in single acting use only. |
| A5 | Pneumatic connection block, converts ND71_ connections to 1/4 NPT. Material AlSi1Mg, anodized grey. Connections 1/4 NPT (S, C1, C2). Only for ND7100. |
| D3 | D3 Non oil filled, dry pressure gauges, scale bar/psi/kPa and kg/cm ² , basic material brass, nickel plated, housing stainless steel. Temperature range -40 °C to +85 °C / -40 °F to +185 °F. Pneumatic connection block, material AlMgSi1, anodized grey. Connections 1/4 NPT (S, C1, C2), converts also ND91_ connections to 1/4 NPT. |
| D3B | As D3 but two pressure gauges with connections 1/4 NPT (S, C2). Converts also ND91_ connections to 1/4 NPT. Use with in single acting use only. |

| CONNECTION PLUGS | |
|--|---|
| Not to be used together with conduit entry nipples (CE_) or cableglands (CG_). | |
| P1H | ND7100 (HART): Connection plug according to M20x1.5 / DIN 43650A (ISO 4400). |

| DRIVER SETS | |
|---|--|
| Driver sets including the needed parts when assembling ND7000 on rotary actuators with VDI/VDE 3845 attachment face or Neles standard mounting faces. Select the correct driver set according to the actuator and the pneumatic connections of valve controller or gauge block when applicable. Note! Earlier the DS04 was delivered with bareshaft positioners as default. This practice is no longer valid, the needed driver set must be ordered as an accessory. | |
| DS01 | Driver set for ND7100 on actuators with VDI/VDE3845 attachment face. Set includes the G1/4 plug for single acting actuators. The driver set should also be applied with all ND7/9 with gauge blocks A1, A1B, A2 or A6. |
| DS02 | Driver set for ND7200 on actuators with VDI/VDE 3845 attachment face. Set includes the 1/4NPT plug for single acting actuators. The driver set should also be applied with all ND with gauge blocks A3, A3B, A5, A7 or A10. |
| DS04 | General driver set for ND7100/72000 on actuators with VDI/VDE 3845 and Neles standard attachment face (e.g. when replacing NE/NP7 or ND800 with S2 shaft). Earlier default driver set. Includes 1/4NPT and G1/4 plugs when used with single acting actuators. |

| 3RD PARTY MOUNTING SETS | |
|--|---|
| Mounting sets between the ND7000 valve controllers and linear actuators, including bracket and ball joint based feedback system. Note! Sets are including the pneumatic plugs needed when used with single acting actuators. Note! All available mounting sets listed in http://neles.mountingkitsonline.com/ | |
| MS01 | Mounting set for linear actuators, attachment face according to IEC 60534-6, stroke length 10-55 mm. (H116240) |
| MS02 | Mounting set for linear actuators, attachment face according to IEC 60534-6, stroke length 55-120 mm. (H120404) |
| MS03 | Mounting set for Masoneilan 87/88 actuators, sizes 6...23. Stroke length 12-64 mm. (H120809) |

| Remote mounting accessories | | |
|-----------------------------|----------|--|
| | ID code | Description |
| RR01 | C0217108 | ND remote mount rotary sensor QNCOK05HDM |
| RR02 | C0215954 | ND remote mount rotary sensor QNCAK05HDM |
| RC01 | H144183 | Cable assembly remote mount sensor cable 1.2 m, straight connector |
| RC02 | H126145 | Cable assembly remote mount sensor cable 3.0 m, angle connector |
| RC03 | H127093 | Cable assembly remote mount sensor cable 30 m, angle connector |

Valmet Flow Control Oy

Vanha Porvoontie 229, 01380 Vantaa, Finland.

Tel. +358 10 417 5000.

www.valmet.com/flowcontrol

Subject to change without prior notice.

Neles, Neles Easyflow, Jamesbury, Stonel, Valvcon and Flowrox, and certain other trademarks, are either registered trademarks or trademarks of Valmet Oyj or its subsidiaries in the United States and/or in other countries.

For more information www.neles.com/trademarks

