

## METSO NELES HIGH PERFORMANCE VALVE, METAL SEATED SERIES BW

Neles BW series metal seated high performance butterfly valve with one piece body design, for both control and tight shut-off applications. Multiple body options makes it particularly well suited for the refining, power, petrochemical and chemical industries.

The BW provides extended operational life in control, tight shut-off and critical applications such as high cycle, high temperature, cryogenic, oxygen and abrasive applications, etc. Rating from ASME 900 to 2500 makes the BW a sound control or shut-off valve in severe service applications.

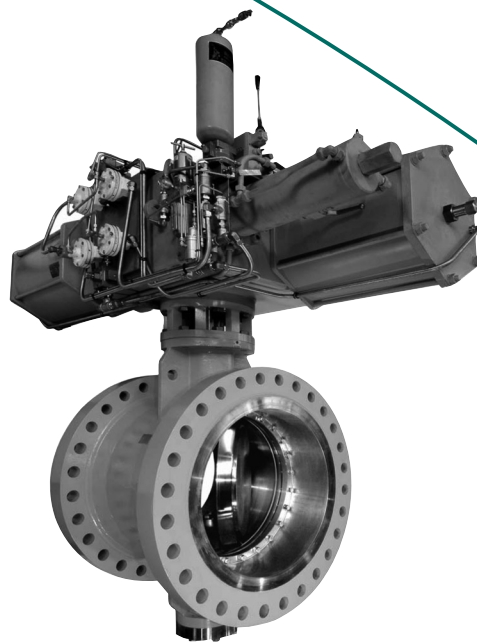

### Excellent on-off capabilities

- Uniquely functioning full metal seat design assures tightness over long time periods.
- Contact between disc and seat is mechanically induced and does not rely on assistance from differential pressure.
- Long term tightness is maintained even in high cycle rate services. Tightness is not compromised by large thermal cycling either.
- Low friction and excellent wear resistance.
- Lowered operational torque reduces actuator size
- Heavy-duty stem and ingenious bearings design extends service life and is insensitive to thermal cycles and impurities.

### Excellent flow control capabilities

- Good controllability via smoothly rising installed characteristic curve at both very small openings and nearly full Cv positions. Series BW provides very wide rangeability in fairly low pressure drop services.
- Good dynamic stability in both flow directions.
- Available with a variety of actuators, positioners and accessories for single source responsibility. Mounting face according to ISO 5211.

### Abrasion resistant construction

- Solid, sturdy all metal seat design is based on metal-to-metal contact. No resilient parts are needed for seating.

### Low emissions

- The live loaded gland packing is located right after the outer bearing maximizing the tightness. The emissions are well below the international standards.
- Furthermore, there are no resilient parts exposed to the medium.

### Extremely wide pressure and temperature range

- Differential pressure/temperature ratings in accordance with ASME B16.34.
- Extremely wide temperature range up to +1150°C / +2100 °F.

### Low cost of ownership

- Extremely high cycle life minimizes the need for maintenance, and increases Mean Time Between Failure (MTBF) value.
- Interchangeable seat can be replaced without disassembling the disc and shaft. Seat replacement does not require any adjustment or special tools.

### Certified emission and fire safe performance

- Emission certified according to industry standard, ISO 15848-1 class B in shut-off applications.
- Fire safe certification according to API 607, 6th edition

### Certified safety performance

- SIL certification to meet IEC61508 requirements
- Capable to SIL 3 level

### Applications

The BW series butterfly valve is suitable for the following industries and applications.

<b>Industry:</b>	<b>Application:</b>
Chemical Process,	Tail gas, waste water
	Flue gas, styrene, acrylic acid
Refinery	Flammable media, process, gas
Off-shore	Flammable media, process, gas
Steel	Gas and crude gas
Gas	Natural gas, sour gas
Nuclear power	Steam, gas, water
Conventional power	Steam, gas, water

### Special features

Metso has provided solutions for special applications including, but not limiting to following examples:

- Valve with heating jacket together with purging
- Valve with double sealing element
- Double block and bleed applications (DBB)
- Flashing and purging of the sealing elements and bearings
- Solid proof design including protection for bearings and sealing element
- Live-loading with seal gas connection

Emergency shut-down design (ESD) for safety applications

## TECHNICAL SPECIFICATIONS

### Valve ratings

- ASME 900, 1500 and 2500
- EN/DIN PN150, PN250, PN400
- ISO PN150, PN250, PN400

### Engineering standards

In accordance with ASME B16.34 and the valve meets the requirements of the European Directive 97/23/EC relating to pressure equipment directive (PED).

### Sizes and end connection types

ASME cl. 900 is available in sizes 6" - 24".  
 ASME cl. 1500 is available in sizes 6"-24".  
 ASME cl. 2500 is available in sizes 6"-18".  
 Other sizes on request

### Inherent flow characteristic

Standard: Equal percentage

### Standard shut-off classifications

Standard tightness:  
 ISO 5208, rate D

### Optional tightness

- ANSI Class V
- ANSI Class VI
- API 598

### Safety features

- Fire-tested per API 607, 6th edition
- Fugitive emission control with live loaded stem sealing as standard, ISO 15848, TA-Luft/VDI 2440 and Shell 77/312
- Rugged single piece body eliminates potential leak paths associated with jointed bodies
- Positive shaft blow-out prevention
- Quadruple bearing construction eliminates jamming

### Flow Data

Cv [gal/min] at 90°, Carbon steel valves									
Body-trim	150	200	250	300	350	400	450	500	600
rating	06	08	10	12	14	16	18	20	24
0900_0300	612	1451	2869	4515	5670	7593	10420	12698	18973
0900_0600	422	1075	2329	3561	4608	6039	8773	10787	16492
0900_0900	345	936	1962	2819	4033	5460	7618	8814	13589
1500_0300	521	1164	2533	3981	5094	6860	9837	10499	17026
1500_0600	417	982	2010	3388	4444	5845	8233	8884	13797
1500_0900	364	905	1588	2798	3803	4884	6763	7414	12051
1500_1500		528	1047	1876	2532	3507	4297	4735	7939
2500_0300	306	798	1748	2558	3991	5469	7421		
2500_0600	281	746	1572	2352	3522	4487	6237		
2500_0900	264	663	1347	1921	2839	3772	5347		
2500_1500		346	838	1384	1808	2392	3559		

Cv [gal/min] at 90°, only for Stainless steel valves									
Body-trim	150	200	250	300	350	400	450	500	600
rating	06	08	10	12	14	16	18	20	24
0900_0300	345	936	1962	2819	4033	5460	7618	8814	13589
0900_0600	not available in SS								
0900_0900	not available in SS								
1500_0300	364	905	1588	2798	3803	4884	6763	7414	12051
1500_0600		528	1047	1876	2532	3507	4297	4735	7939
1500_0900	not available in SS								
1500_1500	not available in SS								
2500_0300	264	663	1347	1921	2839	3772	5347		
2500_0600		346	838	1384	1808	2392	3559		
2500_0900	not available in SS								
2500_1500	not available in SS								

EXPLODED VIEW

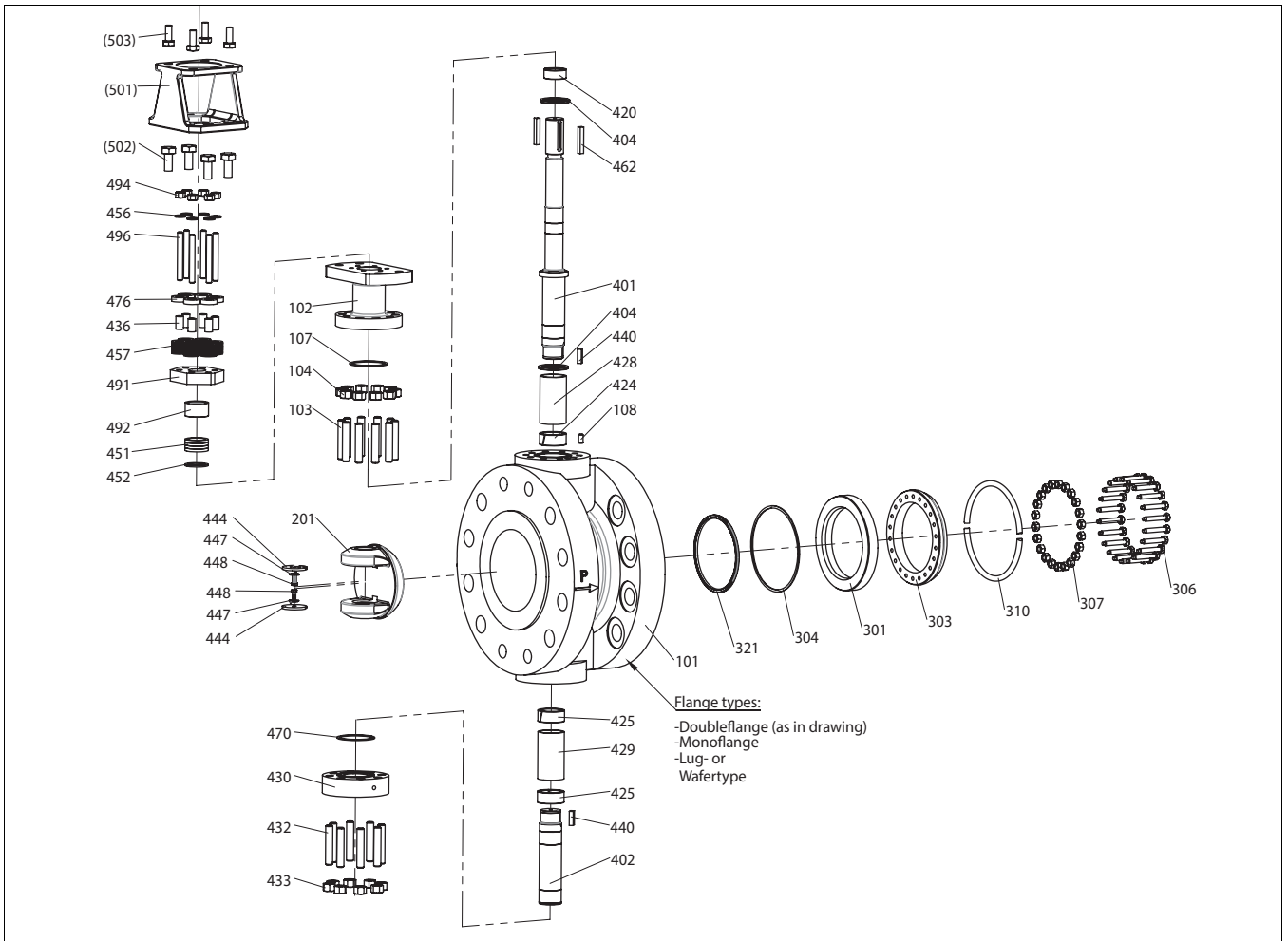

PART LIST

Part nr.	Qty.	Description	Material
101	1	Body	ASTM A217 gr. WC6
102	1	Extension	ASTM A217 gr. WC6
103	variable	Stud	ASTM A193 gr. B7
104	variable	Hexagonal nut	ASTM A194 gr. 7
107	1	Seal	GRAPHITE
108	1	Socket head set screw	A2 STAINLESS STEEL
201	1	Disc	EN 10213-1.4931+ENP
301	1	Seal ring	ASTM A182 gr. F12 cl.2
303	1	Ring	ASTM A182 gr. F12 cl.2
304	1	Seal	GRAPHITE
306	variable	Hexagon screw	ASTM A193 gr. B7
307	variable	Hexagonal nut	ASTM A194 gr. 7
310	1	Retaining ring	EN 10302-1.4923
321	1	Sealing element	EN 10302-1.4923+Ag
401	1	Drive shaft	1.4923+Al2O3/TiO2
402	1	Shaft	1.4923+Al2O3/TiO2
404	2	Thrust washer	EN 13835-0.7660
420	1	Bearing sleeve	EN 13835-0.7660
424	1	Bearing sleeve	EN 13835-0.7660
425	2	Bearing sleeve	EN 13835-0.7660
428	1	Spacer ring	AISI 304
429	1	Spacer ring	AISI 304

Part nr.	Qty.	Description	Material
430	1	Cover	ASTM A182 gr. F12 cl.2
432	variable	Stud	ASTM A193 gr. B7
433	variable	Hexagon nut	ASTM A194 gr. 7
436	6	Sleeve	AISI 316
440	variable	Feather key	EN 10302-1.4923
444	2	Clamp disc	AISI 316
447	2	Shim	A2 STAINLESS STEEL
448	2	Hexagon screw	ISO 3506 A2-70
451	4	Packing ring	GRAPHITE
452	1	Anti extrusion ring	AISI 316
456	6	Washer	AISI 316
457	72	Disc spring	DIN 17222-1.8159
462	1	Feather key	EN 10302-1.4923
470	1	Seal	GRAPHITE
476	6	Spring washer	AISI 316
491	1	Gland	AISI 316
492	1	Compression sleeve	AISI 316
494	6	Hexagonal nut	ASTM A194 gr. 8M
496	6	Stud	ASTM A193 gr. B8M2 cl. 2B
501	1	Bracket	AISI 316
502	variable	Hexagon screw	ISO 3506 A2-70
503	variable	Hexagon screw	ISO 3506 A2-70

**DIMENSIONS**

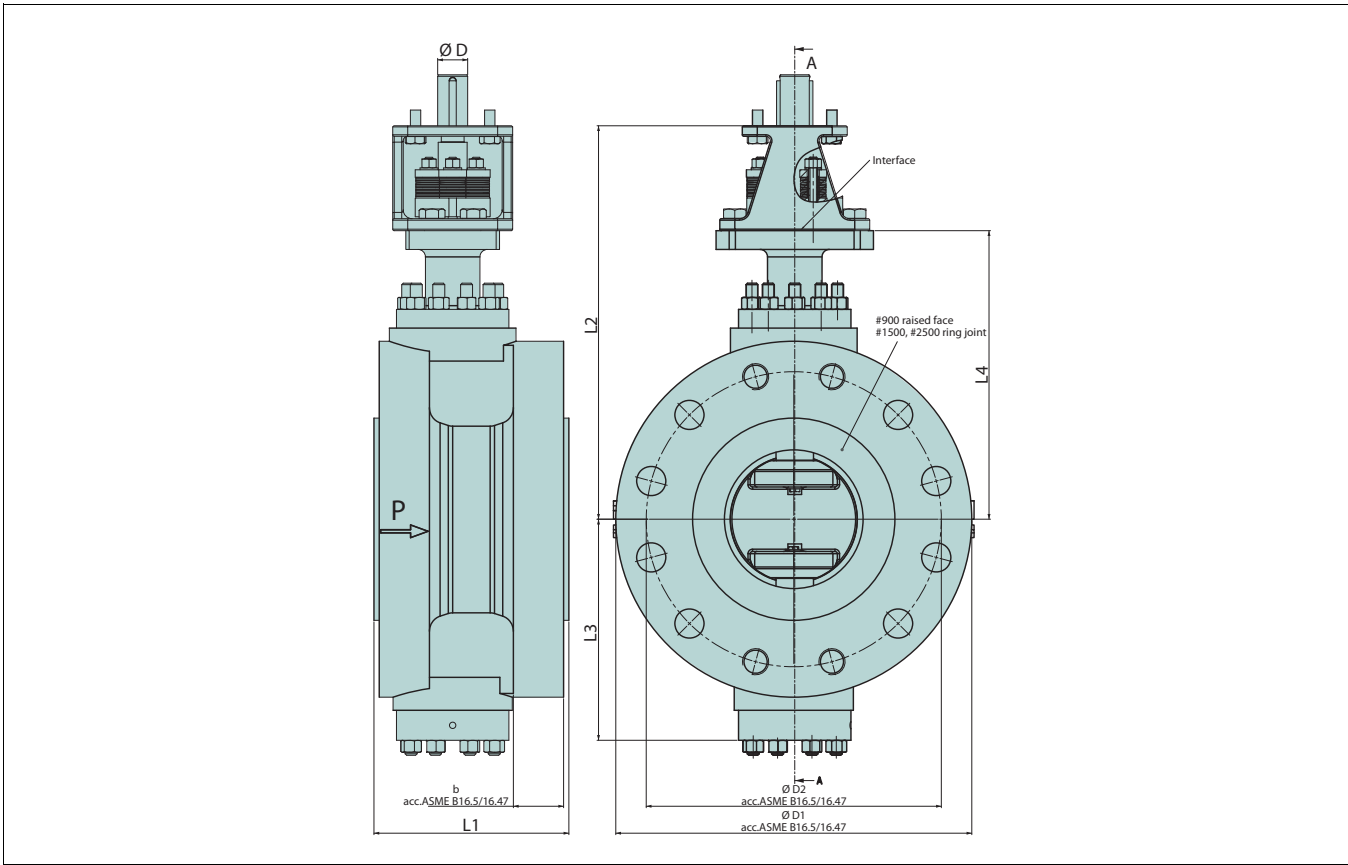

**L1 (short pattern, double flanged)**

Body-trim	150	200	250	300	350	400	450	500	600	DN
rating	06	08	10	12	14	16	18	20	24	NPS
0900/0300	222	260	285	335	355	390	440	485	570	
0900/0600	222	260	285	335	355	390	440	485	570	
0900/0900	222	260	285	335	355	390	440	485	570	
1500/0300	286	330	374	418	450	508	530	582	660	
1500/0600	286	330	374	418	450	508	530	582	660	
1500/0900	286	330	374	418	450	508	530	582	660	
1500/1500		330	374	418	450	508	530	582	660	
2500/0300	376	418	522	570	640	690	740			
2500/0600	376	418	522	570	640	690	740			
2500/0900	376	418	522	570	640	690	740			
2500/1500		418	522	570	640	690	740			

**L3**

Body-trim	150	200	250	300	350	400	450	500	600	DN
rating	06	08	10	12	14	16	18	20	24	NPS
0900/0300	235	295	330	365	375	410	460	495	590	
0900/0600	235	295	330	365	380	420	460	500	595	
0900/0900	235	295	330	370	390	425	465	505	600	
1500/0300	255	305	360	405	445	485	535	565	660	
1500/0600	255	305	365	405	450	485	535	570	665	
1500/0900	255	305	365	415	450	500	550	580	680	
1500/1500		310	370	425	465	510	560	590	695	
2500/0300	300	340	410	455	515	570	615			
2500/0600	300	340	410	465	525	570	630			
2500/0900	300	355	420	465	535	585	635			
2500/1500		355	430	480	540	600	665			

**L2**

Body-trim	150	200	250	300	350	400	450	500	600	DN
rating	06	08	10	12	14	16	18	20	24	NPS
0900/0300	470	525	610	645	665	740	790	820	970	
0900/0600	470	525	610	655	670	750	785	825	975	
0900/0900	475	525	610	655	680	745	790	885	980	
1500/0300	490	535	655	690	735	775	865	895	1045	
1500/0600	490	535	655	690	740	815	865	895	1060	
1500/0900	490	545	655	705	745	825	885	915	1065	
1500/1500		595	655	710	800	845	900	980	1080	
2500/0300	535	590	705	750	805	880	965			
2500/0600	535	590	705	750	820	880	970			
2500/0900	535	590	705	755	830	885	980			
2500/1500		65D	710	760	875	935	1005			

**L4**

Body-trim	150	200	250	300	350	400	450	500	600	DN
rating	06	08	10	12	14	16	18	20	24	NPS
0900/0300	205	255	290	325	335	365	415	450	540	
0900/0600	205	255	290	325	335	375	415	450	540	
0900/0900	205	255	290	325	345	375	415	450	540	
1500/0300	215	255	315	350	395	430	480	510	595	
1500/0600	215	255	315	350	395	430	480	510	595	
1500/0900	215	255	315	360	395	440	480	510	595	
1500/1500		255	315	360	395	440	480	510	595	
2500/0300	250	295	350	395	445	505	550			
2500/0600	250	295	350	395	445	505	550			
2500/0900	250	295	350	395	455	505	550			
2500/1500		295	35D	400	455	505	550			

**Shaft diameter ØD:**

Body-trim	150	200	250	300	350	400	450	500	600	DN
rating	06	08	10	12	14	16	18	20	24	NPS
0900/0300	30	40	50	55	65	65	75	85	95	
0900/0600	30	40	50	55	65	75	75	85	95	
0900/0900	35	40	50	55	65	75	85	95	105	
1500/0300	30	40	50	55	65	65	75	85	95	
1500/0600	30	40	50	55	65	70	75	85	95	
1500/0900	35	40	50	55	65	75	85	85	95	
1500/1500		45	50	65	70	75	85	95	120	
2500/0300	30	40	50	50	55	65	65			
2500/0600	30	40	50	50	55	65	70			
2500/0900	30	40	50	50	65	65	75			
2500/1500		50	50	55	70	75	85			

**Actuator mounting interface**

Body-trim	150	200	250	300	350	400	450	500	600	DN
rating	06	08	10	12	14	16	18	20	24	NPS
0900/0300	160-55	160-55	230-90	230-90	230-90	330-120	330-120	330-120	360-135	
0900/0600	160-55	160-55	230-90	230-90	230-90	330-120	330-120	330-120	360-135	
0900/0900	160-55	160-55	230-90	230-90	230-90	330-120	330-120	360-135	360-135	
1500/0300	160-55	160-55	230-90	230-90	230-90	230-90	330-120	330-120	360-135	
1500/0600	160-55	160-55	230-90	230-90	230-90	330-120	330-120	330-120	360-135	
1500/0900	160-55	160-55	230-90	230-90	230-90	330-120	330-120	330-120	360-135	
1500/1500		230-90	230-90	230-90	330-120	330-120	330-120	360-135	360-135	
2500/0300	160-55	160-55	230-90	230-90	230-90	230-90	330-120			
2500/0600	160-55	160-55	230-90	230-90	230-90	230-90	330-120			
2500/0900	160-55	160-55	230-90	230-90	230-90	230-90	330-120			
2500/1500		230-90	230-90	230-90	330-120	330-120	330-120			

**Weight**

Body-trim	150	200	250	300	350	400	450	500	600	DN
rating	06	08	10	12	14	16	18	20	24	NPS
0900/0300	145	249	339	501	571	745	1015	1293	2219	
0900/0600	145	251	354	505	582	770	1041	1318	2262	
0900/0900	147	261	359	515	597	774	1059	1385	2311	
1500/0300	217	360	535	349	1096	1461	1890	2404	3773	
1500/0600	218	361	587	850	1106	1492	1901	2424	3821	
1500/0900	218	366	591	368	1122	1518	1954	2455	3893	
1500/1500		385	536	906	1192	1604	2056	2596	4101	
2500/0300	424	595	1142	1537	2211	3003	4080			
2500/0600	424	595	1140	1550	2234	3017	4118			
2500/0900	424	606	1148	1561	2259	3053	4143			
2500/1500		642	1179	1604	2383	3225	4322			

**Torque:**

Body-trim	150	200	250	300	350	400	450	500	600	DN
rating	06	08	10	12	14	16	13	20	24	NPS
0900/0300	658	1233	2089	2923	4470	5810	8205	10689	16806	
0900/0600	680	1293	2175	3114	4645	7102	8587	11138	18002	
0900/0900	734	1283	2279	3316	5046	7430	10020	14140	20850	
1500/0300	664	1190	1978	2857	4526	5614	7513	9667	15156	
1500/0600	659	1190	2091	2919	4656	6003	7983	9859	16188	
1500/0900	724	1183	2114	3146	4343	6776	9294	10555	17450	
1500/1500		1605	2330	3882	6237	8395	10533	15599	25656	
2500/0300	660	1148	1957	2378	3829	5175	6137			
2500/0600	660	1148	2006	2405	3930	5192	6494			
2500/0900	660	1138	2041	2439	4455	5374	7557			
2500/1500		1324	2267	3033	5855	7573	10154			

### HOW TO ORDER

1.	2.	3.	4.	5.	6.	7.	8.	9.	10.	11.	12.	13.	14.
BW	3	G/D	1	B	56	P	N2	A	N	T3	-	05	-

1. sign	PRODUCT SERIES / DESIGN
BW	Metal seated Neles butterfly valve, available as double flanged, lug, wafer or butt weld end type.

2. sign	BODY CONSTRUCTION
2	Flanged, long pattern
3	Flanged, short pattern
4	Lug or mono flange or single flange
6	Wafer
7	No entry + butt weld ends
8	Top entry, side access + butt weld ends
9	Top entry, top access + butt weld ends
Y	Special, to be specified

3. sign	BODY PRESSURE RATING	3. sign	TRIM PRESSURE RATING Use trim rating e.g. /C if not full rated
G	ASME class 900	/D	ASME class 300
H	ASME class 1500	/F	ASME class 600
H	ASME class 1500	/G	ASME class 900
1	ASME class 2500	/C	ASME class 150
		/H	ASME class 1500
		/I	ASME class 2500

BW1H/F...-> full rated body #1500, de-rated trim #600. Corresponding PN pressure classes also available.

4. sign	SEAT DESIGN
1	U-Type metal seat with coating (sign 11).
2	Double seat, metal + soft (Tmax limited by soft seat). Max pressure 100 bar.
4	Double seat on valve body + leak off connection between the seat.
8	Solid proof. One sealing ring on the disc + seat on the body.
Y	Special construction

5. sign	BEARING AND BODY DESIGN
A	Soft bearings, PTFE or eq. on metal net Tmax 250 °C, trim rating max #600.
B	Metallic or carbon bearings for high temperature. (e.g. GGG-CrNi or stellite or high performance carbon bearings). Tmax 500 °C.
H	Metallic or carbon bearings for high temperature. (e.g. GGG-CrNi or stellite or high performance carbon bearings). Temp: 500-850 °C.
HH	H + cooling ribbons. (e.g. GGG-CrNi or stellite or high performance carbon bearings) cooling ribbons. Temp: 850-1150 °C.
S	Construction B + steam jacket.
Y	Special construction

For NACE, add "N" to sign. 6 "B" -> "BN"

6. sign	SIZE
	<b>Note:</b> Pressure rating = ASME -> inch sizes Pressure rating = PN -> metric sizes
BW	<b>Inch:</b> 04, 06, 08, 10, 12, 14, 16, 18, 20, 24, bigger sizes on request <b>Metric:</b> 100, 150, 200, 250, 300, 350, 400, 450, 500, 600, bigger sizes on request

NOTE:  
- The factory will keep the right to change the material if the material is same e.g. from casting to forged  
- With slash "/" the materials are double marked

7. sign	BODY	8. sign	DISC	9. sign	SHAFT, PINS AND KEY
A	ASTM A351 CF8M / 1.4408	A	ASTM A351 CF8M / 1.4408	N	ASTM A479 XM-19
P	ASTM A216 WCB / 1.0619	N2	ASTM A487 CA6NM / 1.4317	C	ASTM SA564 Gr. 630
				C2	ASTM A638_660 / 1.4980

NOTE: Check the recommend material combination from the factory

10. sign	SEAT MATERIAL
F	ASTM A182 gr. F6NM/1.4313 + silver coated T= -75°C ... +425°C;
D	U-type metallic seat, UNS 07718 + silver coated T= -200°C ... +850°C
E	U-type metallic seat, 1.4021 + silver coated T= -20°C ... +400°C
C	1.4923 + silver coated T = 0°C ... + 600°C

11. sign	PACKING CONSTRUCTION
T3	Live loaded PTFE packing
T2	Live loaded PTFE double packing with one 1/4" NPT leak off connection for shaft seal
G1	Live loaded graphite packing, compatible to GOX/LOX".
G3	Live loaded graphite packing. Inherently firesafe
G2	Live loaded graphite double packing with one 1/4" NPT leak off connection for shaft seal. Inherently firesafe.

12. sign	SURFACE FINISH FOR PIPE FLANGE FACE
-	Ra 3.2 - 6.3, standard, without sign Cover: EN 1092-1 Type B1 (Ra 3.2 - 12.5) ASME B16.5, Ra 3.2 - 6.3 (125 - 250 µm) DIN 2526 Form E (Ra 4)

13. sign	SPECIAL FLANGE FACING TYPES/FORMS always check suitability from factory
05	Ring joint
06	DIN EN 1092-1 Form F (tongue)
16	ANSI B16.5 large tongue (Ra 3.2)
Y	Special, to be specified

14. sign	FLANGE in marked flanges always check suitability from factory
-	without sign according to valve body pressure rating PN-rating · EN1092-1 ASME-rating · ASME B 16.5 #150-#1500 size 4 - 24, #2500 size max 12" · ASME B 16.47 Series B #150 - 600 size 26" -60". #900 size max 48" · Bigger flange drilling has to be agreed with the factory. · Butt weld ends acc. ASME B16.25, Pipe diameter and pipe class to be defined
A	ASME 16.47 Series A (size 26" and bigger), pls consult factory for suitability
Y	To be specified



**Metso Corporation**

Töölönlahdenkatu 2, PO Box 1220, 00100 Helsinki, Finland  
Tel. +358 20 484 100  
<http://contact.metso.com/>

**Metso Flow Control Inc.**

Vanha Porvoontie 229, P.O. Box 304, FI-01301 VANTAA, Finland.  
Tel. +358 20 483 150. Fax +358 20 483 151

[www.metso.com/valves](http://www.metso.com/valves)

Subject to change without prior notice. Product names in this bulletin are all trademarks of Metso Flow Control Inc.

