

Neles Easyflow™ concentric disc resilient seated butterfly valves Series JA

JA series concentric disc resilient seated butterfly valves are suitable for a wide range of applications in manual or automated on/off through throttling control services. Although compact and lightweight, the JA series is designed to be rugged, reliable, and to comply with a variety of global industry standards. Complete package reliability and single source responsibility available with actuators, switches, and intelligent valve controllers.



Technical description

- Wafer or lug body type available
- Single piece cast body
- Rugged, bonded elastomeric cartridge seal is easily replaceable
- Bi-directional bubble-tight shut-off to full rated pressure
- Suitable for vacuum service
- Compatible with EN, ASME, JIS raised or flat face flange bolt patterns
- Face-to-face dimension complies with API 609 Table 2 for Category A valves
- Seal design extends to flanges – no need for additional flange gaskets
- Valve body is powder coated for excellent corrosion resistance
- CE marked, conforming to European PED 2014/68/EU

Features



- ISO 5211 mounting pad for direct mounting of handle, gear operator, manual override, or actuator
- An extremely tight fit square drive between the stem and disc provides accurate and repeatable shut-off and control
- Bonded seal is the most rugged method of construction available, providing consistent operating torque, maximum cycle life, and higher flow velocities in control. Avoids pinching and tearing that can occur with non-bonded seal designs

- Bonded elastomeric cartridge seal is easy to remove and replace if maintenance is ever needed
- Disc is precision machined with a spherical disc edge to provide long cycle life
- Two-piece stem arrangement for highest Cv and maximum flow
- Top and bottom stems have anti blow-out protection that also prevents lifting or pushing of the disc during actuator installation or removal
- Lower stem includes groove for easy servicing
- The burnished stem is supported by self lubricating polymer bearings to minimize deflection and provide smooth operation and long life
- Every valve is factory tested, serialised & quality tagged prior to shipment
- If unidirectional electric actuator is used, valve is capable of 360 deg. disc rotation
- Standards followed include ISO 5211, API 598, API 609, ASME B16.5 for Class 150 flanges, BS EN 593

Applications

- Water and waste water
- Sewage treatment
- Mining and other slurries
- Fuel oil and gas

- Cooling or chilled water circuits
- Desalination
- HVAC
- Cement and other fine powders
- Mild corrosive chemicals and petrochemicals

Exploded view and parts list

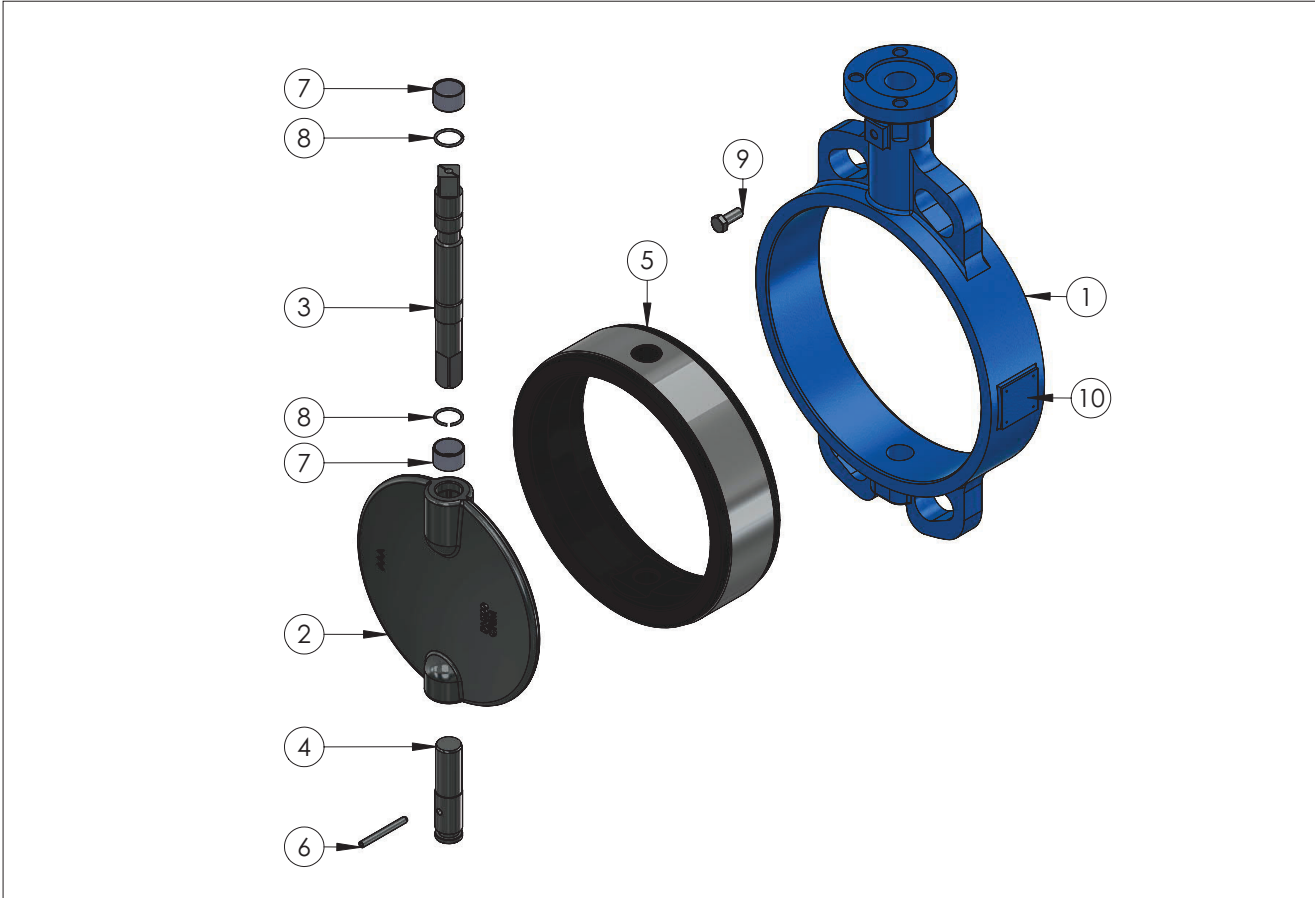

Part no.	Part name	Material
1	Body	GGG40 Ductile iron GG25 Cast iron WCB Carbon steel CF8M Stainless steel
2	Disc	GGG40 Ductile iron (powder coated) CF8M Stainless steel Bronze ASTM B148 C958 Ni-Al-Bronze
3	Top stem	316 Stainless steel 410 Martensitic steel S31803 Duplex Stainless
4	Bottom stem	316 Stainless steel 410 Martensitic steel S31803 Duplex stainless

Part no.	Part name	Material
5	Seal	Ethylene Propylene (EPDM) Nitrile, Buna-N (NBR) Fluoroelastomer (FKM) Silicone (VMQ) EPDM White Hydrogenated Nitrile (HNBR) Bonded metal backing is Aluminum for DN50 - 300, and carbon steel for DN350 and larger
6	Spring dowel	Stainless steel
7	Bushing	Self lubricating polymer
8	Spring ring	Spring steel
9	Anti-blowout bolt	Stainless steel
10	Label	Stainless steel

Please contact Valmet for any other material specification.

Technical specifications

Nominal diameter:	DN50 – DN600 (NPS 2 – 24)	Vacuum rating:	29.91 inch Hg gauge (759.98 mm Hg gauge or 2×10^{-2} Torr or 4×10^{-4} psia or 99.99% vacuum)
Pressure rating:	PN10, PN16, ASME Class 150	Leakage:	No visible leakage
Flange accommodation:	EN1092 (PN10, PN16) ASME B16.5 Class 150 JIS 10K, 16K Refer to flange table for availability by size	Standards followed	ISO 5211, API 598, API 609, ASME B16.5, BS EN 593, IS 13095, CE-PED 2014/68/EU
Face to face dimension:	Per API 609 Table 2 for Category A BS EN 558 Table 2 Series 20 valves	Testing:	API 598, EN 12266-1

Working temperature

Temperature rating, °C	
Body or disc material	-50 -45 -40 -35 -30 -25 -20 -15 -10 -5 0 5 10 15 20 25 30 35 40 45 50 55 60 65 70 75 80 85 90 95 100 105 110 115 120 125 130 135 140 145 150 155 160 165 170 175 180 185 190 195 200
GGG40 ductile iron	-5° to +200 °C
GG25 cast iron	-5° to +200 °C
WCB carbon steel	-29° to +200 °C
CF8 stainless steel	-50° to +200 °C
CF8M stainless steel	-50° to +200 °C
NiAlBronze	-50° to +200 °C
Seal material	
Ethylene-Propylene (EPDM)	-30° to +120 °C
Nitrile (NBR, Buna-N)	-30° to +85 °C
Fluoroelastomer (FKM)	-5° to +180 °C
Silicone (VMQ)	-25° to +200 °C
White Ethylene-Propylene (EPDM White)	-30° to +80 °C
Hydrogenated Nitrile (HNBR)	-30° to +100 °C

Seal materials

Seal material	Code	Service	Temperature range
Ethylene-Propylene (EPDM) Standard	EP	Excellent resistance to heat, ozone, hot water and steam, as well as dilute acids, detergents, alkalis, silicone oils and greases, ketones, and alcohols. Not compatible with petroleum oils, mineral oils, kerosene, aromatic, gasoline, and halogenated solvents	-30° to +120 °C
Nitrile (NBR, Buna-N) Standard	NB	Most widely used seat with excellent resistance to abrasion. Compatible with petroleum fuels, mineral oils, vegetable oils, dilute acid, alcohols, and alkalines. Not suitable for use with ozone, ketones, chlorinated solvents, benzene, toluene, and steam.	-30° to +85 °C
Fluoroelastomer FKM Optional	VT	Excellent resistance to heat, oxidation, dilute acids, gasoline, kerosene, and fuel oils. Good resistance to strong bases, and aromatic hydrocarbons such as benzene and toluene. Poor resistance to hot water, steam, alcohols, alkalis, ketones, glycol based brake fluids, hot hydrofluoric or chlorosulfonic acids.	-5° to +180 °C
Silicone (VMQ) Optional (not used for >PN10)	SL	Widest temperature range, but has limited abrasion resistance (lower cycle life). Excellent resistance to ozone, oxygen, methanol, ethanol, and water. Not compatible with acids, alkalis, petroleum based fluids, ketones, chlorinated solvents, or steam.	-25° to +200 °C
White Ethylene-Propylene (EPDM White) Optional	EW	Excellent resistance to heat, ozone, hot water and steam, as well as dilute acids, detergents, alkalis, silicone oils and greases, ketones, and alcohols. Not compatible with petroleum oils, mineral oils, kerosene, aromatic, gasoline, and halogenated solvents	-30° to +80 °C
Hydrogenated Nitrile (HNBR) Optional	HN	Higher strength NBR for increased high temperature and abrasion resistance. Low temperature performance is decreased. Compatible with ozone, polar and non-polar media. Excellent resistance to mineral and petroleum based oils, coolants, and fuel.	-30° to +100 °C

Cv VALUES

Size		Cv
DN	NPS	100 %
50	2	158
65	2 1/2	331
80	3	528
100	4	732
125	5	1 484
150	6	2 048
200	8	4 601
250	10	6 115
300	12	8 313
350	14	10 293
400	16	13 589
450	18	16 585
500	20	21 186
600	24	29 211

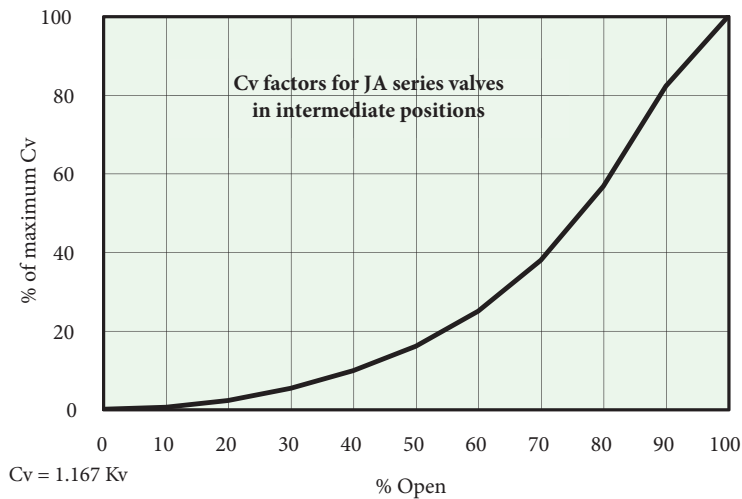

% open	% Cv
0	0
10	0,5
20	2,2
30	5,3
40	9,8
50	16
60	25
70	38
80	57
90	82
0.25 pt	100

Actuator selection torque for service condition 1

Valve size		Torque for PN3.5, PN6		Torque for PN10, PN16, Class 150	
DN	NPS	N,m	lb-ft	N,m	lb-ft
50	2	9	7	15	11
65	2 1/2	14	11	23	17
80	3	20	15	32	24
100	4	34	26	44	33
125	5	54	40	80	59
150	6	86	64	135	100
200	8	157	116	225	166

Valve size		Torque for PN3.5, PN6		Torque for PN10, PN16, Class 150	
250	10	268	198	330	244
300	12	428	316	510	376
350	14	608	449	750	553
400	16	784	579	1 050	775
450	18	1205	889	2 400	1770
500	20	1603	1183	3 800	2803
600	24	2955	2180	6 000	4425

Note: The actuator selection torque includes safety factor. Select actuator that has equal or greater torque output.

Service condition No.	Media	Corrosion	Cycling frequency	Torque increase factor
1	Clean liquids and lubricating hydrocarbons	None	At least once per week	0
2	Humid or lubricating gases, aqueous liquids, clean salt water	Insignificant	Once per month	Multiply Condition 1 torque by 1.2
3	Dry gas, cement and other powders, high viscosity liquid	Disc will corrode or seat will swell	A few times per year	Multiply Condition 1 torque by 1.4

Note: Service condition number is determined by worst case of media or corrosion or cycling frequency. Each reviewed independently.

Flange compatibility

Size		Flanges						
DN	NPS	ASME (WAFER & LUG)	EN 1092 (WAFER & LUG)		JIS (WAFER)		JIS (LUG)	
		CL 150	PN10	PN16	10K	16K	10K	16K
50	2	√	√	√	√	Not available	√	Not available
65	2 1/2	√	√	√	√	Not available	√	Not available
80	3	√	√	√	√	√	√	√
100	4	√	√	√	√	√	√	√
125	5	√	√	√	Not available	√	√	√
150	6	√	√	√	√	Not available	√	Not available
200	8	√	√	√	Not available	Not available	√	√
250	10	√	√	√	√	√	√	Not available
300	12	√	√	√	Not available	Not available	Not available	Not available
350	14	√	√	√	√	Not available	√	√
400	16	√	√	√	√	Not available	√	√
450	18	√	√	√	√	Not available	√	Not available
500	20	√	√	√	√	Not available	√	Not available
600	24	√	√	√	Not available	Not available	Not available	Not available

Dimensions

(All dimensions are in mm)

WAFFER BODY WITH CENTERING LUG

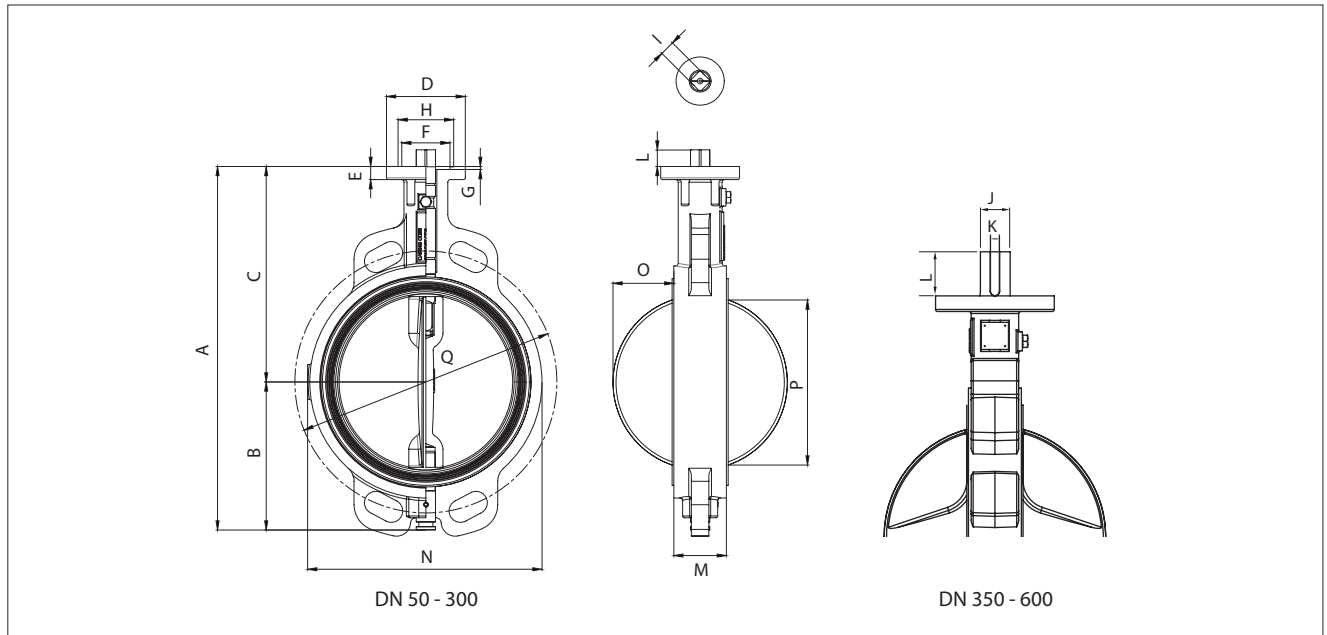

Note: Dimension P is minimum mating pipe ID to ensure clearance with disc

	DN50	DN65	DN80	DN100	DN125	DN150	DN200	DN250	DN300	DN350	DN400	DN450	DN500	DN600
A	206	224	252	272	318	349	422	478	551	644	700	759	832	1002
B	76	78	89	102	118	131	176	209	253	288	320	348	380	457
C	130	146	163	170	200	218	246	269	301	356	380	411	450	546
D	65	65	65	65	90	90	90	125	125	175	175	175	175	210
E	12	12	12	12	15	15	15	18	18	23	23	23	23	25
F	35	35	35	35	55	55	55	70	70	100	100	100	100	130
G	3.5	3.5	3.5	3.5	3.5	3.5	3.5	3.5	3.5	5	5	5	5	7
H	F05	F05	F05	F05	F07	F07	F07	F10	F10	F14	F14	F14	F14	F16
I	14	14	14	14	17	17	17	22	22	-	-	-	-	-
J	-	-	-	-	-	-	-	-	-	Ø45	Ø45	Ø45	Ø45	Ø70
K	-	-	-	-	-	-	-	-	-	14	14	14	14	20
L	16	16	16	16	19	19	19	24	24	65	65	65	65	80
M	43	46	46	52	56	56	60	68	78	78	102	114	127	154
N	96	107	130	153	182	213	268	323	389	440	480	540	600	705
O	8	13	20	28	37	50	70	91	105	125	134	152	185	225
P		67	78.5	101	123	148	195	243	279	317	359	411	470	566
Q PN10	125	145	160	180	210	240	295	350	400	460	515	565	620	725
Q PN16	125	145	160	180	210	240	295	355	410	470	525	585	650	770
Q ANSI 150	120.65	139.7	152.4	190.5	215.9	241.3	298.45	361.95	431.8	476.25	539.8	577.9	635	749.3
Q 10K	120	140	150	175	210	240	290	355	400	445	510	565	620	730
Q 16K	120	140	160	185	225	260	305	380	430	480	540	605	660	770
Weight (kg)	2	2.5	3	4	6	8	14	21	40	63	87	113	149	279

LUG BODY

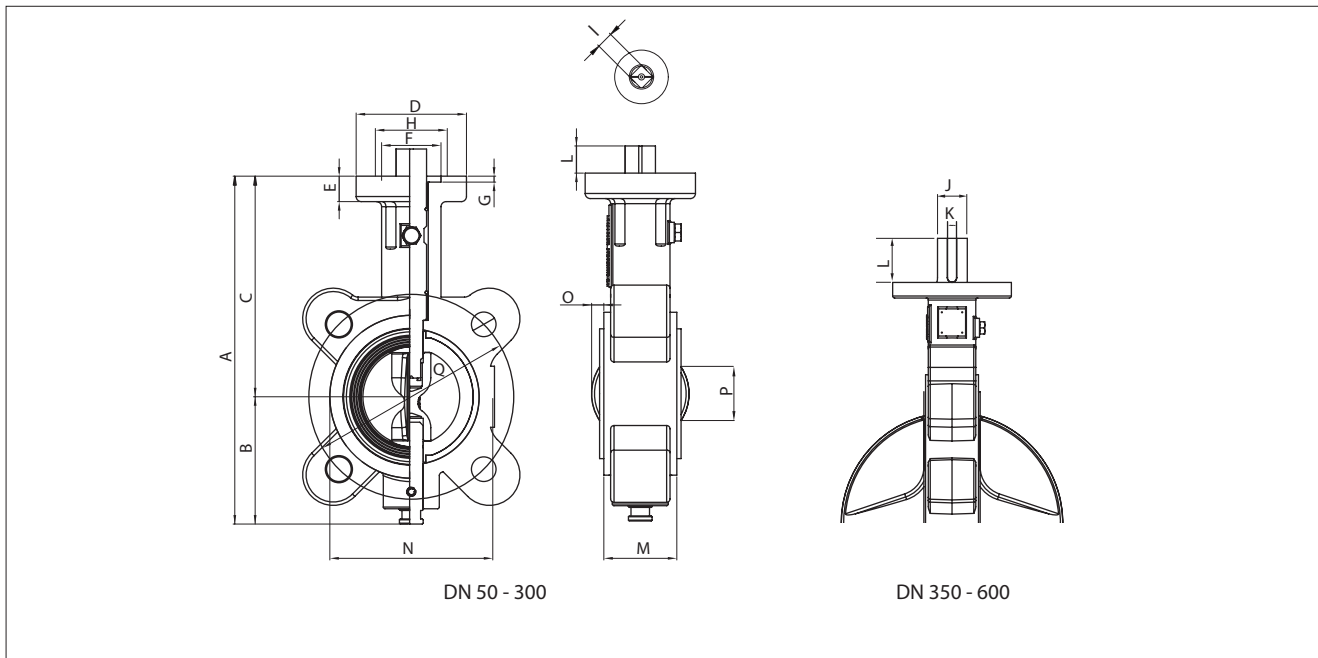

Note: Dimension P is minimum mating pipe ID to ensure clearance with disc

	DN50	DN65	DN80	DN100	DN125	DN150	DN200	DN250	DN300	DN350	DN400	DN450	DN500	DN600
A	206	224	257	288	332	361	416	466	551	644	700	759	832	1002
B	76	78	94	110	132	143	170	197	250	288	320	348	380	457
C	130	146	163	170	200	218	246	269	301	356	380	411	450	546
D	65	65	65	65	90	90	90	125	125	175	175	175	175	210
E	15	12	15	15	15	15	15	18	18	23	23	23	23	25
F	35	35	35	35	55	55	55	70	70	100	100	100	100	130
G	3.5	3.5	3.5	3.5	3.5	3.5	3.5	3.5	3.5	5	5	5	5	7
H	F05	F05	F05	F05	F07	F07	F07	F10	F10	F14	F14	F14	F14	F16
I	14	14	14	14	17	17	17	22	22	-	-	-	-	-
J	-	-	-	-	-	-	-	-	-	Ø45	Ø45	Ø45	Ø45	Ø70
K	-	-	-	-	-	-	-	-	-	14	14	14	14	20
L	16	16	16	16	19	19	19	24	24	65	65	65	65	80
M	43	46	46	52	56	56	60	68	78	78	102	114	127	154
N	96	107	130	153	182	213	265	323	389	440	480	540	600	705
O	8	13	20	28	37	50	70	91	105	125	134	152	185	225
P	52	67	78.5	101	123	148	195	243	279	317	359	411	470	566
Q PN 10	125	145	160	180	210	240	295	350	400	460	515	565	620	725
Q PN 16	125	145	160	180	210	240	295	355	410	470	525	585	650	770
Q ANSI 150	120.65	139.7	152.4	190.5	215.9	241.3	298.45	361.95	431.80	476.25	539.8	577.9	635	749.3
Q 10K	120	140	150	175	210	240	290	355	400	445	510	565	620	730
Q 16K	120	140	160	185	225	260	305	380	430	480	540	605	660	770
Weight (kg)	5	6	6	7	9	11	17	25	49	74	98	134	189	325

Actuator selection

Selected rack and pinion actuator sizes in the chart are based on the recommended minimum actuator torque and 4 barg minimum air supply pressure. Selected spring return actuator size is suitable for fail open or fail close configuration. Unless otherwise specified, actuator will be set for fail close.

Actuators may be direct mounted or direct mounted with sleeve or mounted using bracket & coupler. For all these cases, the mounting sets include respective fasteners in addition to the above said components.

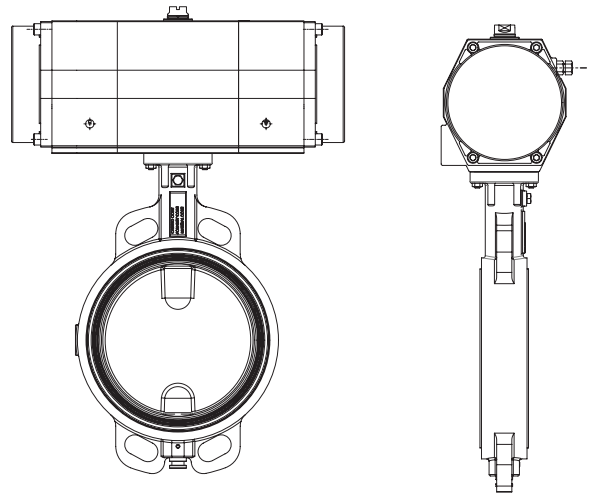

DOUBLE ACTING Rack & pinion actuator sizing (PN10, PN16, Class 150), 4 barg min. air supply

Valve size		Service condition		
DN	NPS	1	2	3
50	2		RNP 63	
65	2 1/2		RNP 63	
80	3		RNP 63	RNP 80
100	4		RNP 80	
125	5		RNP 90	RNP 100
150	6	RNP 100	RNP 110	RNP 125
200	8	RNP 125		RNP 150
250	10		RNP 150	RNP 175
300	12	RNP 175		RNP 200
350	14		RNP 200	RNP 250
400	16		RNP 250	
450	18		RNP 350	B1C32
500	20		B1C32	B1C40
600	24		B1C40	

SPRING RETURN Rack & pinion actuator sizing (PN10, PN16, Class 150), 4 barg min. air supply (Fail close or open)

Valve size		Service condition		
DN	NPS	1	2	3
50	2	RNP 63 SR40		RNP 80 SR40
65	2 1/2	RNP 80 SR40		RNP 90 SR40
80	3		RNP 90 SR40	RNP 100 SR40
100	4		RNP 100 SR40	RNP 110 SR40
125	5		RNP 125 SR40	RNP 150 SR40
150	6	RNP 150 SR40		RNP 175 SR40
200	8		RNP 200 SR40	
250	10	RNP 200 SR40		RNP 250 SR40
300	12	RNP 250 SR40		RNP 300 SR40
350	14	RNP 300 SR40		RNP 350 SR40
400	16	RNP 350 SR40	B1JV20, B1JA20	B1JK25, B1JKA25
450	18	B1J25, B1JA25	B1JV25, B1JA25	B1JK32, B1JKA32
500	20		B1J32, B1JA32	B1JV32, B1JVA32
600	24	B1JV32, B1JVA32		B1J40, B1JA40

Note: For B1J series actuators, the 3rd digit 'A' in code means actuator is for Spring to open operation

DOUBLE ACTING Rack & pinion actuator sizing for undercut disc (PN3.5 & PN6), 4 barg min. air supply

Valve size		Service condition		
DN	NPS	1	2	3
50	2		RNP 63	
65	2 1/2		RNP 63	
80	3		RNP 63	
100	4		RNP 80	
125	5		RNP 80	RNP 90
150	6		RNP 90	RNP 100
200	8	RNP 110		RNP 125
250	10		RNP 150	
300	12		RNP 175	
350	14		RNP 200	
400	16	RNP 200		RNP 250
450	18		RNP 250	RNP 300
500	20		RNP 300	RNP 350
600	24	RNP 350		B1C32

SPRING RETURN Rack & pinion actuator sizing for undercut disc (PN3.5 & PN6), 4 barg min. air supply (Fail close or open)

Valve size		Service condition		
DN	NPS	1	2	3
50	2		RNP 63 SR40	
65	2 1/2	RNP 63 SR40		RNP 80 SR40
80	3		RNP 80 SR40	RNP 90 SR40
100	4		RNP 90 SR40	RNP 100 SR40
125	5	RNP 100 SR40		RNP 125 SR40
150	6	RNP 125 SR40		RNP 150 SR40
200	8	RNP 150 SR40		RNP 200 SR40
250	10		RNP 200 SR40	RNP 250 SR40
300	12		RNP 250 SR40	RNP 300 SR40
350	14		RNP 300 SR40	RNP 350 SR40
400	16	RNP 300 SR40		RNP 350 SR40
450	18		B1JV20, B1JVA20	B1JK25, B1JKA25
500	20	B1JK25, B1JKA25		B1J25, B1JA25
600	24	B1JV25, B1JVA25		B1J32, B1JA32

Note: For B1J series actuators, the 3rd digit 'A' in code means actuator is for Spring to open operation

Actuator mounting set

RNP actuators

Valve size	Actuator model	Mounting set number
DN50 (2)	RNP 63	EASYFLOW MOUNTING SET 1
	RNP 80	EASYFLOW MOUNTING SET 6
DN65 (2.1/2)	RNP 63	EASYFLOW MOUNTING SET 1
	RNP 80	EASYFLOW MOUNTING SET 6
	RNP 90	EASYFLOW MOUNTING SET 6
DN 80 (3)	RNP 63	EASYFLOW MOUNTING SET 1
	RNP 80	EASYFLOW MOUNTING SET 6
	RNP 90	EASYFLOW MOUNTING SET 6
	RNP 100	EASYFLOW MOUNTING SET 22
DN 100 (4)	RNP 80	EASYFLOW MOUNTING SET 6
	RNP 90	EASYFLOW MOUNTING SET 6
	RNP 100	EASYFLOW MOUNTING SET 22
	RNP 110	EASYFLOW MOUNTING SET 22
DN 125 (5)	RNP 80	EASYFLOW MOUNTING SET 2
	RNP 90	EASYFLOW MOUNTING SET 2
	RNP100	EASYFLOW MOUNTING SET 7
	RNP 125	EASYFLOW MOUNTING SET 23
DN 150 (6)	RNP 150	EASYFLOW MOUNTING SET 24
	RNP 100	EASYFLOW MOUNTING SET 7
	RNP 110	EASYFLOW MOUNTING SET 7
	RNP 125	EASYFLOW MOUNTING SET 23
	RNP 150	EASYFLOW MOUNTING SET 24
DN 200 (8)	RNP 175	EASYFLOW MOUNTING SET 24
	RNP 100	EASYFLOW MOUNTING SET 7
	RNP 125	EASYFLOW MOUNTING SET 23
	RNP 150	EASYFLOW MOUNTING SET 24
DN 250 (10)	RNP 200	EASYFLOW MOUNTING SET 25
	RNP 150	EASYFLOW MOUNTING SET 8
	RNP 175	EASYFLOW MOUNTING SET 50
	RNP 200	EASYFLOW MOUNTING SET 9
	RNP 250	EASYFLOW MOUNTING SET 26
DN 300 (12)	RNP 250	EASYFLOW MOUNTING SET 26
	RNP 175	EASYFLOW MOUNTING SET 50
	RNP 200	EASYFLOW MOUNTING SET 9
DN 350 (14)	RNP 250	EASYFLOW MOUNTING SET 27
	RNP 200	EASYFLOW MOUNTING SET 10
	RNP 250	EASYFLOW MOUNTING SET 11
	RNP 300	EASYFLOW MOUNTING SET 29
DN 400 (16)	RNP 350	EASYFLOW MOUNTING SET 30
	RNP 200	EASYFLOW MOUNTING SET 10
	RNP 250	EASYFLOW MOUNTING SET 11
DN 450 (18)	RNP 350	EASYFLOW MOUNTING SET 30
	RNP 250	EASYFLOW MOUNTING SET 11
DN 500 (20)	RNP 250	EASYFLOW MOUNTING SET 11
	RNP 300	EASYFLOW MOUNTING SET 29
DN 600 (24)	RNP 350	EASYFLOW MOUNTING SET 30
	RNP 350	EASYFLOW MOUNTING SET 136

B-Series actuators

Valve size	Actuator model	Mounting set number
DN 400 (16)	B1JV20, B1VA20	EASYFLOW MOUNTING SET 129
	B1JK25, B1JKA25	EASYFLOW MOUNTING SET 30
DN 450 (18)	B1J20	EASYFLOW MOUNTING SET 129
	B1J25, B1JA25 B1JV25, B1JVA25	EASYFLOW MOUNTING SET 130
	B1C32, B1J32, B1JK32, B1JKA32	EASYFLOW MOUNTING SET 131
DN 500 (20)	B1J25	EASYFLOW MOUNTING SET 130
	B1C32, B1J32, B1JA32, B1JV32, B1JVA32	EASYFLOW MOUNTING SET 131
	B1C40	EASYFLOW MOUNTING SET 132
	B1J25	EASYFLOW MOUNTING SET 133
DN 600 (20)	B1C32, B1J32, B1JV32, B1JVA32	EASYFLOW MOUNTING SET 134
	B1C40, B1J40, B1JA40	EASYFLOW MOUNTING SET 135

Hand lever with 10 position notch plate

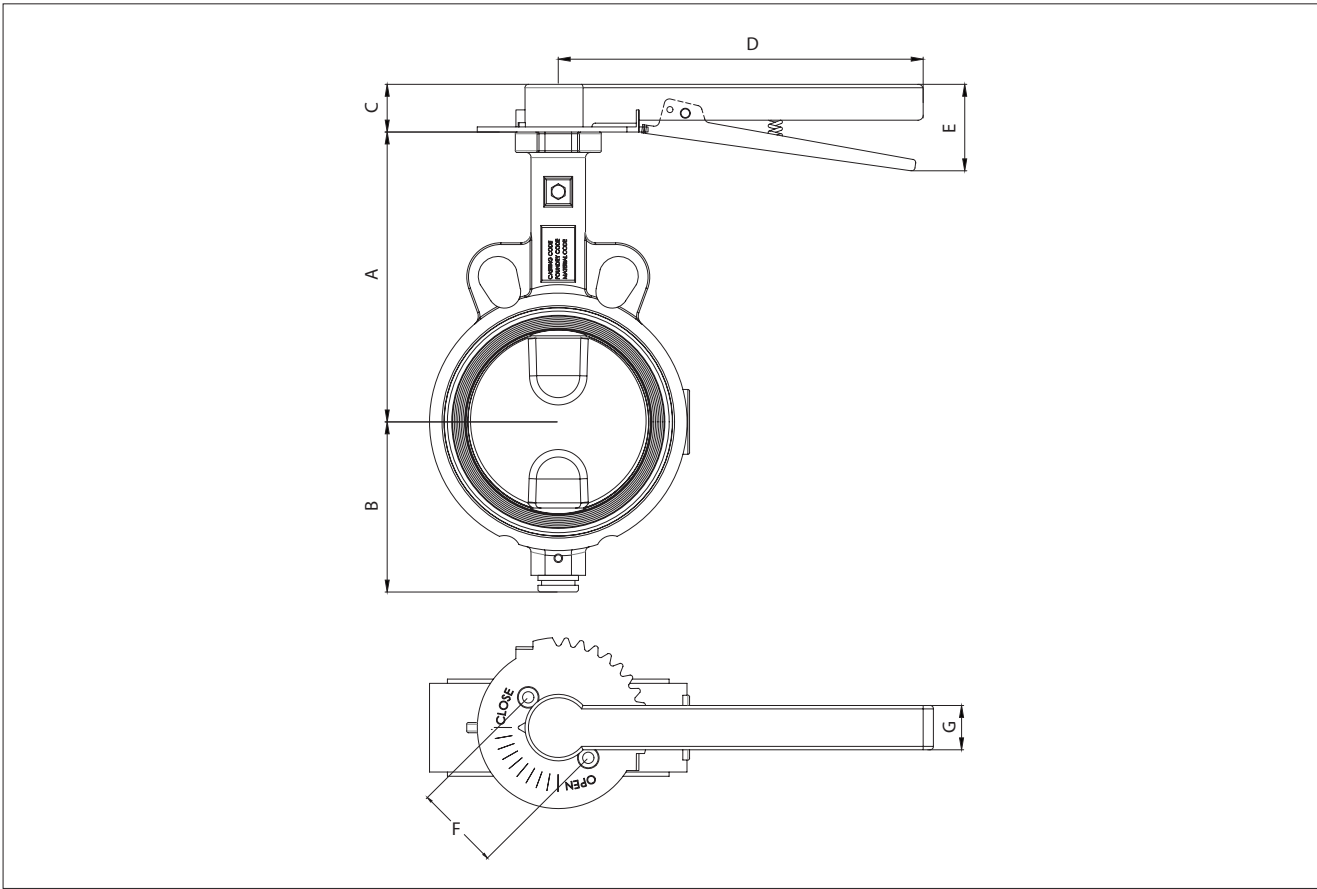

MODEL	SIZE	A	B	C	D	E	F	G	Handle Force, N			Mounting set number
									Condition 1	Condition 2	Condition 3	
RHL 141	DN50	130	75	30	250	60	F05	22	71	85	99	EASYFLOW MOUNTING SET 51
RHL 141	DN65	146	78	30	250	60	F05	22	108	132	151	EASYFLOW MOUNTING SET 51
RHL 141	DN80	163	89	30	250	60	F05	22	151	179	212	EASYFLOW MOUNTING SET 51
RHL 141	DN100	186	102	32	250	60	F05	22	208	250	292	EASYFLOW MOUNTING SET 51
RHL 171	DN125	200	118	32	250	60	F07	22	377	453	528	EASYFLOW MOUNTING SET 52

Hand lever is powder coated steel. Notch plate, spring, and bolts are zinc plated steel.

Manual gear operator

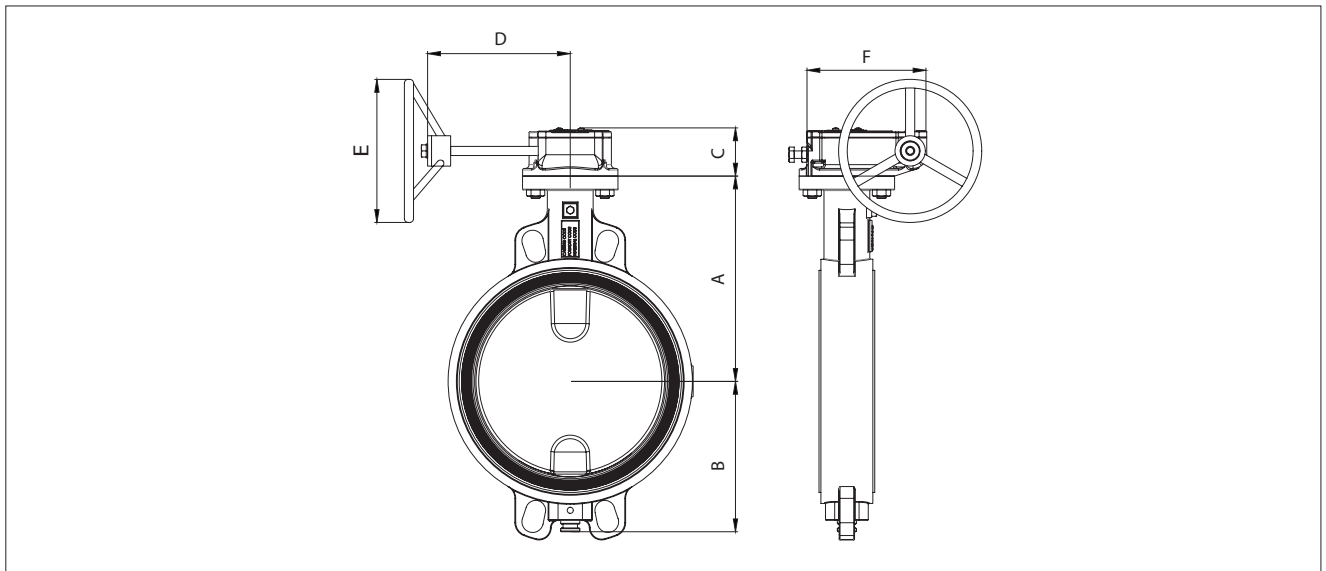

MODEL	TORQUE N.m	SIZE	A	B	C	D	E	F	MOUNTING DETAIL	WEIGHT (kg)	Mounting set number
MEG22514	225	DN50	130	76	58	160	175	96	F05	3.5	EASYFLOW MOUNTING SET 1
MEG22514	225	DN65	146	78	58	160	175	96	F05	4	EASYFLOW MOUNTING SET 1
MEG22514	225	DN80	163	89	58	160	175	96	F05	6	EASYFLOW MOUNTING SET 1
MEG22514	225	DN100	170	102	58	160	175	96	F05	8	EASYFLOW MOUNTING SET 1
MEG22517	225	DN125	200	118	58	160	175	96	F07	13	EASYFLOW MOUNTING SET 2
MEG22517	225	DN150	218	131	58	160	175	96	F07	15	EASYFLOW MOUNTING SET 2
MEG22517	225	DN200	246	169	58	160	175	96	F07	19	EASYFLOW MOUNTING SET 2
MEG35022	350	DN250	269	197	56	113	250	125	F10	27	EASYFLOW MOUNTING SET 3
MEG800	800	DN300	301	250	74	170	350	152	F10	46	EASYFLOW MOUNTING SET 2
MEG1100	1100	DN350	356	288	74	170	350	152	F14	84	EASYFLOW MOUNTING SET 4
MEG1100	1100	DN400	380	320	86	178	350	164	F14	115	EASYFLOW MOUNTING SET 4
MEG2500	2500	DN450	411	348	100	200	500	204	F14	136	EASYFLOW MOUNTING SET 4
MEG5000	5000	DN500	450	380	115	330	600	240	F14	190	EASYFLOW MOUNTING SET 4
MEG6000	6000	DN600	546	454	128	345	600	256	F16	285	EASYFLOW MOUNTING SET 5

Note: Weight is with wafer style body

How to order

1.	2.	3.	4.	5.	6.	7.	8.	9
200	JA	15	W	21	36	41	EP	

1. sign	Size, DN (NPS ref.)
50	50 (2)
65	65 (2 1/2)
80	80 (3)
100	100 (4)
125	125 (5)
150	150 (6)
200	200 (8)
250	250 (10)
300	300 (12)
350	350 (14)
400	400 (16)
450	450 (18)
500	500 (20)
600	600 (24)

2. sign	Series
JA	

3. sign	Flange / rating
10	PN 10
16	PN 16
15	ASME Class 150

4. sign	Body type
W	Wafer type
L	#Lug type

5. sign	Body material
21	GGG40 ductile iron
24	*GG25 cast iron
22	WCB carbon steel
36	CF8M stainless steel

* GG25 body option not available for Class 150

6. sign	Disc material
21	GGG40 ductile iron (powder coated)
36	CF8M stainless steel
12	#Bronze ASTM B148 C958

7. sign	Stem material
36	316 stainless steel
4J	#S31803 Duplex stainless
41	410 martensitic steel

8. sign	Seal material
EP	Ethylene-Propylene (EPDM)
NB	Nitrile (Buna-N, NBR)
VT	#Fluoroelastomer (FKM)
SL	#Silicone (VMQ) (up to PN10 rating only)
EW	#White Ethylene-Propylene
HN	#Hydrogenated Nitrile (HNBR)

Non-standard options

9. sign	Non-standard options
P3	Low torque reduced diameter disc (undercut disc) with PN3.5 shut-off rating
P6	Low torque reduced diameter disc (undercut disc) with PN6 shut-off rating

NOTE: As the use of the valve is application specific, a number of factors should be taken into account when selecting a valve for a given application. Therefore, some of the applications in which the valves are used are outside the scope of this document. If you have any questions concerning the use, application or compatibility of the valve with the intended service, contact nearest Valmet sales office for more information.

Subject to change without prior notice.

Neles, Neles Easyflow, Jamesbury, Stonel, Valvcon and Flowrox, and certain other trademarks, are either registered trademarks or trademarks of Valmet Oyj or its subsidiaries in the United States and/or in other countries.

For more information www.neles.com/trademarks

Valmet Flow Control Oy

Vanha Porvoontie 229, 01380 Vantaa, Finland.

Tel. +358 10 417 5000.

www.valmet.com/flowcontrol

