

The logo for ADAMS, featuring the word "ADAMS" in a bold, white, sans-serif font. The letter "A" is stylized with three parallel diagonal lines extending from its top-left corner. The background is a light gray with a technical drawing grid and several concentric white arcs.

Custom-made valves
Enduring Reliability

Made in Germany



Dear customers and business partners

For more than 50 years now we have been successfully supplying customers all over the world with valves. The reason for the company's success is our concept of being able to offer our customers solutions that suit their individual requirements. This statement is backed up by the fact that apart from our standard products we also specially design a great number of valves tailored to suit customers' special needs and have done so successfully for a great many projects.

We have acquired this expertise in the field of special valves often used in critical areas for innumerable applications in many years of experience since company founder Karl Adams first patented the triple-eccentric valve over 50 years ago. Our ability is also combined with the uncompromising will to initiate new innovations again and again and also to exhaust the modern possibilities of the latest manufacturing technologies. These objectives, however, can only be achieved with the able, motivated staff that forms the backbone of our company. For this reason we are very proud to say that a great number of our employees have already been with the company for many years and some even for decades.

All of these factors are true characteristics of a typical medium-sized, family-run company, which indeed we are. It is important for us is to safeguard this character into the future. One of the key cornerstones in this endeavour is the fact that the third generation of the family is already part of the company's management.

Horst Adams

Martin Adams

The company	Page 6
History	Page 8
Subsidiaries	Page 10
Quality management	Page 12
ADAMS headquarters	Page 16
ADAMS SCHWEIZ AG	Page 18
ADAMS USA	Page 20
Product development	Page 22
Production	Page 24
Staff qualification	Page 30
The applications	Page 32
Overview	Page 34
Fossil-fired power plants	Page 36
Nuclear power plants	Page 38
Hydroelectric power plants	Page 40
District heating	Page 42
Gas industry / LNG	Page 44
Oil industry / petrochemicals industry / FCC / ethylene	Page 46
The products	Page 48
Overview	Page 50
Tight shut-off valve MAK	Page 52
Tight shut-off valve HTK	Page 56
Tight shut-off valves OSK/WAK	Page 58
Throttle valves DSK/ASK	Page 60
Quick-closing and control valve NSK	Page 62
Criteria for decisions	Page 64
Check valves SCV/FCV	Page 66
Check valves MAG/GMZ	Page 68
Check valves RZN/RZI	Page 70
Tight shut-off, throttle and check valves GBZ/AZI	Page 72
Tight shut-off, throttle and check valve GZA	Page 73
Valves for hydroelectric power plants	Page 74
Approvals	Page 76
Sealing systems	Page 78
Closing mechanisms	Page 80
Imprint	Page 83

The company



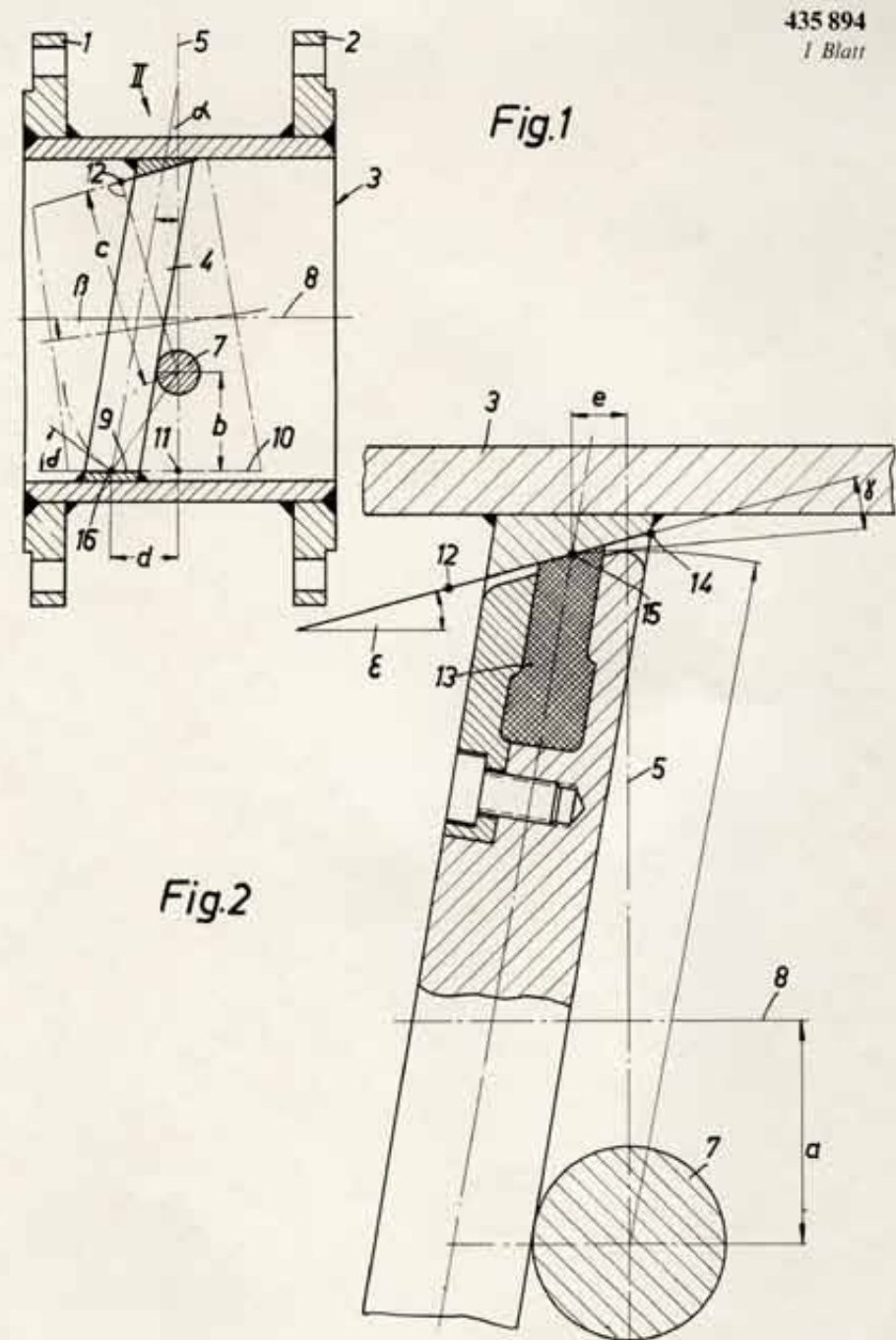

435 894
1 Blatt

Fig.1

Fig.2

“When I registered the first patent for the triple-eccentric sealing system in 1960, I was convinced it would provide the impetus for opening up a new market. I am pleased to confirm that my conviction was well founded and we were able to convince the sceptics of the time. Our company has always been one step ahead of the competition in the field of valves. We plan and develop products that others often do not believe to be feasible. It is not easy to live up to such high expectations but it is an exciting challenge.”

Karl Adams (1898–1983)

ADAMS – the inventor of the triple-eccentric metallic sealing system

Karl Adams pursued a unique concept with his idea of a highly versatile valve. Particularly in the case of metallic seals, it was to set new standards in terms of tightness, service life and range of uses. The resourceful company founder was able to implement this idea by means of gradually improving on the original valve technology to arrive at the triple-eccentric sealing system. The current technology enables the valve to move into its final sealing position without friction.

Innovations: investments in the future

Throughout the 50-year development of the company, one principle has always remained: the ingenuity with which Karl Adams started the company. Only a few years after registering its first patent, the company patented further innovations, such as the metallic seal for valves. The following years saw the constant development of new products and the enhancement of details that led to a great number of additional patents. This innovative power was constantly underpinned by far-sighted investment decisions in state-of-the-art research and production methods.

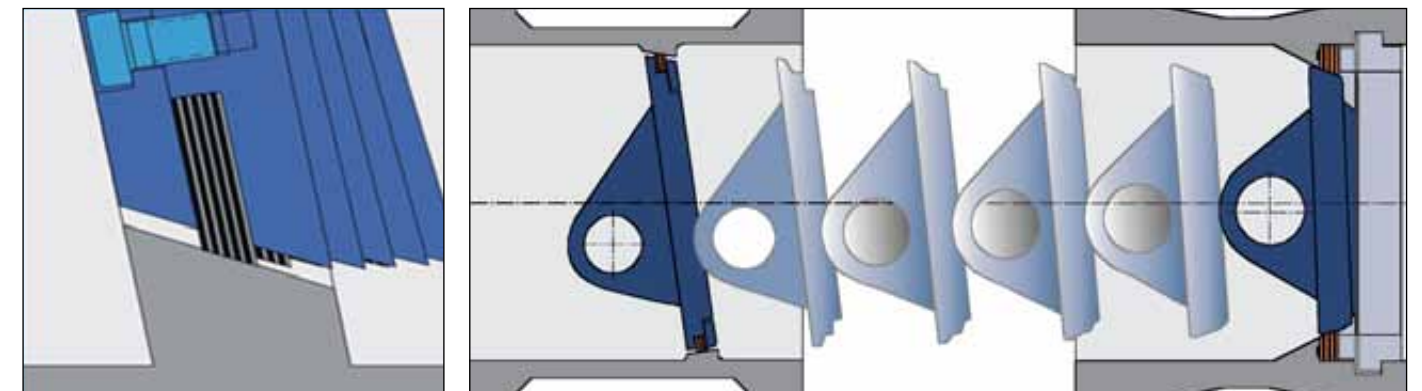

left: One of the special things about the triple-eccentric valve is that the seal on the valve moves without contact and thus without friction right into its final sealing position.

right: Further developments in valve technology over the decades.



Continuity and reliability – worldwide

The company's headquarters and main plant are located in Herne, North Rhine-Westphalia. Distribution, development and production within the company work hand in hand. Rapid decision-making processes are the key to close cooperation for the benefit of our customers – in the typical style of a medium-sized company.

ADAMS Armaturen GmbH has been privately owned by the Adams family for the last 50 years. As a medium-sized company we have established a sound reputation for ourselves among our customers as a reliable partner during this time. Our systematic trainee and further training programme, which we have been promoting for years, also ensures that it will remain that way in the future. Thus a number of leading positions are occupied by young people who have nevertheless worked for the company for many years. A third-generation member of the Adams family is also a member of the board of management, thus ensuring continuity.

A great many of our customers show their appreciation of this constancy with their long-term loyalty. A large number of customers have put their trust in our products over several decades. And rightly so – some of our valves have been in operation for over 50 years. For many of our customers it is also important to know that we are still able to supply spare parts for our old valves. That is reliability.



What we provide

We often receive enquiries including exhaustive specifications that clearly define the valve and its design within a certain framework. In these cases we can quickly and precisely supply the valve to suit the desired requirements. However, just as often we receive enquiries that our wide range of experience enables us to offer solutions for, using various types of valve that had not previously been thought of. In a number of cases, customers ask us to develop valves together with them for special applications. We are able to provide all of these services because of the great scope we have in both development and production.

Wherever you need our support: we are nearby

In 1969, only nine years after the company was founded, Karl Adams established the company's first foreign distribution office: the "Benelux" office in Breda, the Netherlands. Today we have our own distribution offices in 56 countries of the world and thus provide a global network of on-site consultation and service for our customers.

Addresses and contacts of the distribution offices are available at: www.adams-armaturen.com.

Quality awareness

Quality is defined either in accordance with special standards and regulations or by the specifications of our customers. We guarantee the quality of all our products. We work daily to retain this level of quality – systematically and with great attention.

Our employees take great care in everything they do. They have a positive attitude towards their work that cannot be prescribed. It is part of a working culture that has come into being through many years of working together. It is all about the understanding of each individual employee for the quality requirements of our customers, but also as a reflection of the appreciation of their achievements by the executives and management. That is how a key quality factor is established in the company: attention.



Certification in accordance with DIN EN ISO 9001

The ADAMS quality management system in accordance with DIN EN ISO 9001 was certified for the first time in 1993. We have regularly obtained recertification ever since. Our quality management includes two points of central importance that we would additionally like to mention. Firstly, the particularly extensive training and further education of the company's employees (see also pages 30–31) and secondly, the maintaining of the company's own test stands for valves with state-of-the-art testing equipment that we use for scrutinising our finished products and prototypes. That typifies our systematic approach.

National standards and guidelines by which ADAMS is authorised to develop, produce and test:

- AD information sheets
- ANSI
- API
- ASME
- ATEX
- BS
- PED
- DIN EN ISO
- GOST
- KTA
- MSS
- NACE
- RCC-M



Quality tests

Our tests comply with the above-mentioned standards. We perform the testing processes with our own state-of-the-art equipment either personally in-house or in cooperation with well-known testing institutions.

Destruction-free testing procedures

- Dye penetrant test (PT)
- Magnetic particle test (MT)
- Ultrasound test (UT)
- Visual test (VT)
- Leak test (LT)
- Positive Material Identification (PMI)
- X-ray test (RT)



Dye penetrant test



Magnetic particle test



Ultrasound test



Leak test



Positive Material Identification



3-D measuring

Low temperature test
up to $-196\text{ }^{\circ}\text{C}$



Reason enough to perform great feats

As the plant in Herne was acquired in 1972, the company management already planned a long way ahead. The land provided sufficient space to expand and thereby accommodate the twelve production buildings erected so far as well as the administration building. Today, around 200 employees work in the main administration building and at the plant.

Our plant in Herne / Germany covers 70,000 square metres and currently performs practically all production steps required for the manufacture of valves, including welding, mechanical processing, assembling and approval. Only the making of cast parts is outsourced to certified foundries. We also operate a specially designed large-parts production area for manufacturing oversized valves. The broad scope of production that can be provided by the main plant in Herne is in keeping with the high degree of flexibility and quality that we offer our customers.

Apart from administration and production, the Herne site also accommodates the raw materials warehouse as well as finished products. The customers benefit from the fact that a great many standard valves are either on stock or can be promptly delivered.



Hydroelectricity safely under control

Located in the central Alps, our plant in Serneus in the Swiss canton of Graubünden has developed to become a specialist supplier of valves for hydroelectric power stations over the decades. Today customers worldwide make use of our know-how in order to install reliable safety valves in hydroelectric power stations.

ADAMS SCHWEIZ AG has produced valves for hydroelectric power stations at its 8,000-square-metre premises since 1979. Due to its topography and the high average precipitation, Switzerland has a long tradition in the use of hydroelectric power. Today Switzerland generates 56% of its energy from hydroelectric power. Switzerland's hydropower network consists of over 540 hydroelectric power stations. This environment has always offered us the ideal situation in which to develop perfectly coordinated solutions for the requirements of safety valves for hydroelectric power stations.

Long-serving employees guarantee quality

Our employees in Switzerland are our guarantee of the highest quality and precision. Just like at our other locations, our staff have remained loyal to the company over many years, ensuring a high degree of commitment and experience.

Apart from manufacturing valves, we also provide our customers with help when planning new plants or modernising and refurbishing existing plants. The latter point is a key task in view of the need for carbon-optimised energy generation.





Efficiency increased for the American market

ADAMS Valves Inc. has been successfully operating as an independent company in Houston, Texas since 1988. The company optimises the entire range of ADAMS products especially for the American market.

A new production site was inaugurated in Houston in 2010, just in time for the 50th anniversary of the parent company. The newly constructed buildings house the production, the warehouse and the administration on premises covering approximately 7,000 square metres.

The new plant enables ADAMS Valves Inc. to offer its customers in North and Central America even greater efficiency and performance. The increased production capacity and new machinery provide the company with far greater flexibility in satisfying the requirements of customers and thus a far more positive corporate development for the future.



Tailor-made solutions

Product development at Adams has always comprised two main areas: the general development of valves and details and the development of products specially designed for individual customers. One of our main strengths is our ability to reliably develop and implement special design solutions for our customers.

In our view, we can only make real progress if research and development are solidly embedded as integrated corporate tasks. This also includes close interaction with other departments of the company, for example exchanging views with those of the sales department who pose questions straight from the market, or cooperation with the production department regarding the latest technologies, e.g. finishing processes, which enable the engineers' ideas to be implemented in the first place.

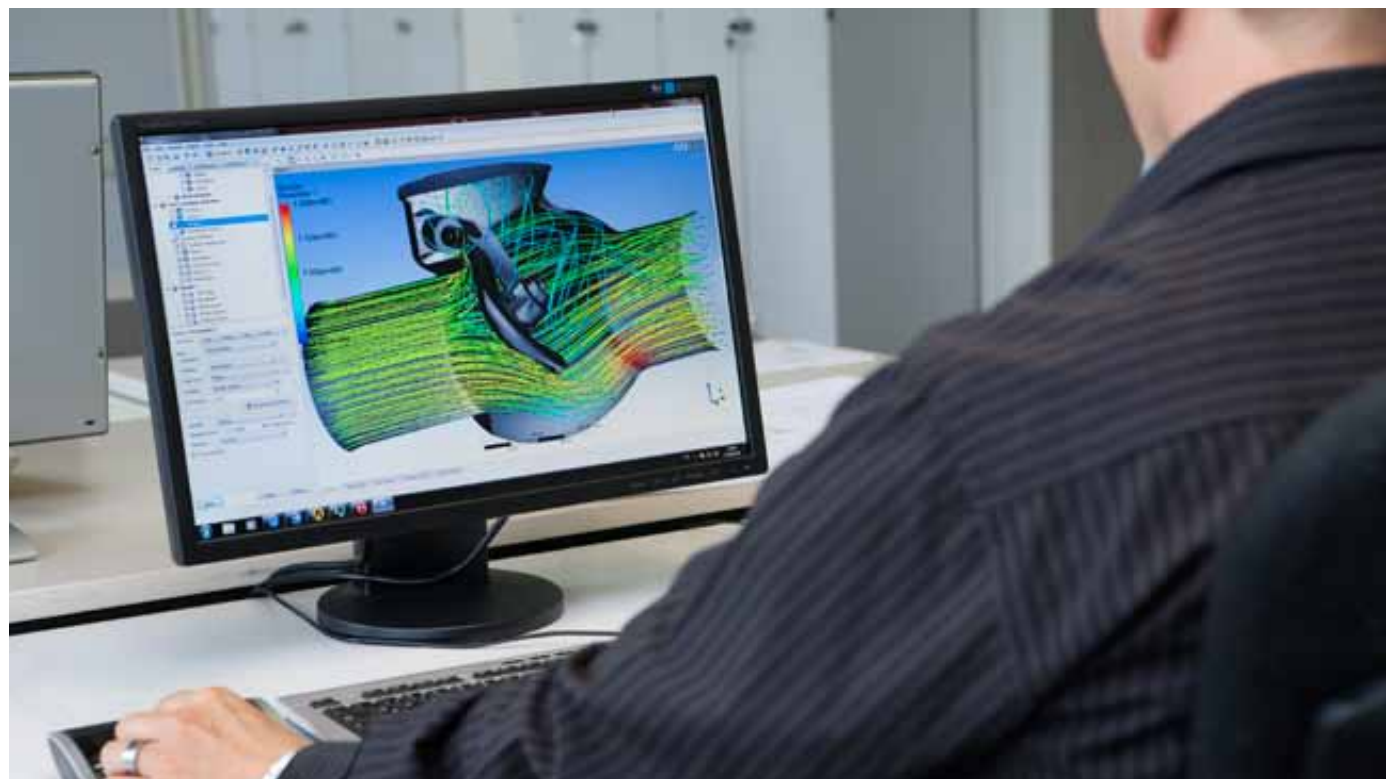

Constant investment in the future

Over and above the previously described communication factors, the outstanding facilities of the departments directly involved with research and development are also of great importance. The foremost of these is the technical office – our engineers already began using the first CAD systems in 1982, the current versions of which are state-of-the-art 3-D systems. We also use, for example, FEM (the finite elements method): this modern method of analysis of structural mechanics is absolutely exact in every detail and enables our experts to precisely calculate our designs. Thus we are able to optimally design our valves to suit their intended purposes and requirements.

With the help of CFD (Computational Fluid Dynamics), the numerical flow simulation, we can precisely map the flow behaviour of each type of medium in our valves. This technology provides us with key information concerning the flow parameters and enables us to arrive at optimal flow behaviour for each type of medium through the deliberate design of our valves. Our engineers have numerous in-house testing systems at their disposal to enable ideas to be tried out prior to their use in actual practice.

Excellent product development

We received the Siemens Supplier Award for the quality of our technical cooperation in the development and construction of twelve turbine safety valves. The power station builder Siemens commissioned us with the development of special valves for the Finnish Olkiluoto nuclear power station. The valves are responsible for safeguarding the steam turbines, which are currently the most powerful in the world with an output of 1,700 megawatts.

For our company this order meant the complete development of a new double-valve 2.80 metre long in order to meet the customer's requirements for the nuclear power station. Receiving the customer's award after three years' development and fine tuning was an incentive for us to continue expanding customer-oriented development within the company in the future.

Innovation guarantees leading edge

Ever since the company's early days, it has always been our maxim to constantly improve production methods and technologies. These endeavours even include developing special production processes together with technical universities. Thus we are able to maintain and secure our lead, both technologically and qualitatively.

Valves in industrial use often have to provide reliable service over several decades. This can only be guaranteed by means of skilful design and high-quality manufacturing. For this reason we have an above-average range of manufacture and produce practically all of the parts for our valves ourselves. This enables us to have quality well under control. The following display several important steps in our chain of production.

Welding shop

All welders and processes are TÜV-approved and regularly certified by renowned testing institutions; all work is carried out according to detailed welding plans. Our welding shop uses both manual and semi-automatic welding processes. The most important of these are Submerged Arc Welding (SAW), Tungsten Inert Gas welding (TIG), Metal Active Gas welding (MAG) and electrode manual welding.



Equipment for submerged arc welding

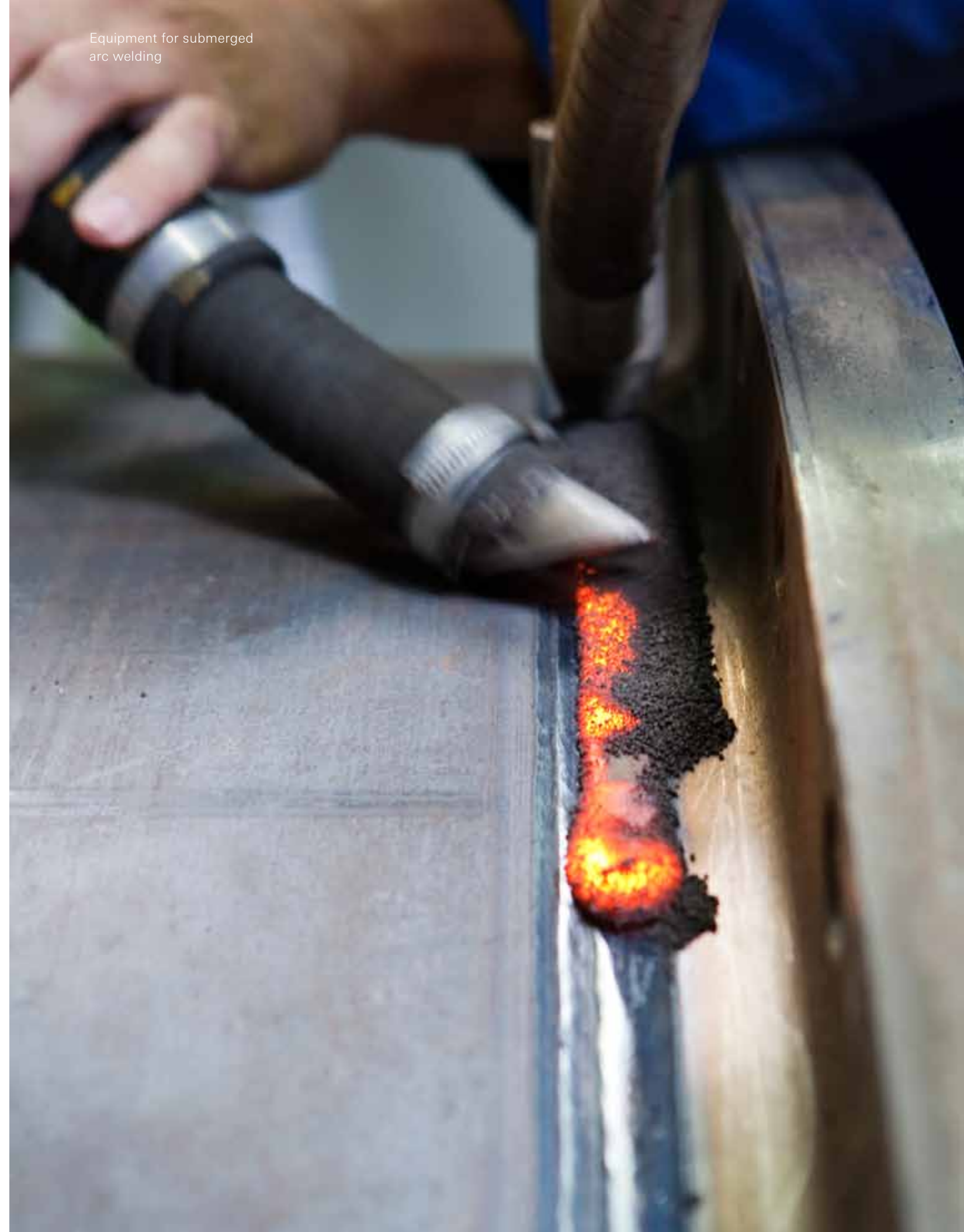



Mechanical processing

Our state-of-the-art CNC machine tools enable us to perform modern 5-axis processing with exact reproducibility. Special equipment is needed to manufacture the complex sealing design of our products. We develop and produce this equipment in-house. The above mentioned CNC machine tools enable us to manufacture individual product elements efficiently and flexibly on-site with a relatively low real net output ratio.

Our department for manufacturing large parts is specially equipped to deal with unusual dimensions.

Assembly

The assembly of our valves, which we design and construct for highly specialised and often critical ranges of application, requires extreme precision and sensitivity. From the standard to the custom-made version, our products, which consist of valve components, assemblies and finished products of various types, are assembled manually with the highest possible degree of precision. Each working step is subject to a continually controlled process. Furthermore, during assembly we equip the valves with various drive options (manual, hydraulic, pneumatic, electric) and precisely adjust the opening, closing, dampening or control behaviour according to the specific requirements in each case. The precision of assembly as well as the subsequent adjustment procedure ensure a valve featuring enduringly reliable processes in line with design and specifications.



Roller, shaft production



Large parts manufacturing

Approval

Prior to delivery our products are all subject to strict approval tests. The tests depend on the intended purpose of use and the accompanying standards and regulations as well as customer-specific guidelines, which are often far stricter than the legally prescribed regulations. Whether classical pressure and leakage tests, function tests under extreme temperature conditions up to -196 °C or $+950\text{ °C}$ or tests using specialised media for precisely determining defined parameters, our extensive testing equipment makes it possible to perform reliable approvals for the requirements of each range of application. These approvals also include simultaneous documentary scrutiny and are exclusively performed under the accompaniment of our quality assurance.

Paint shop

The company has its own paint shop, enabling it to efficiently comply with customers' wishes regarding surface coating if a particular type of surface protection is required for a certain application. Examples of these are hot zone, drinking water or explosion protection applications.

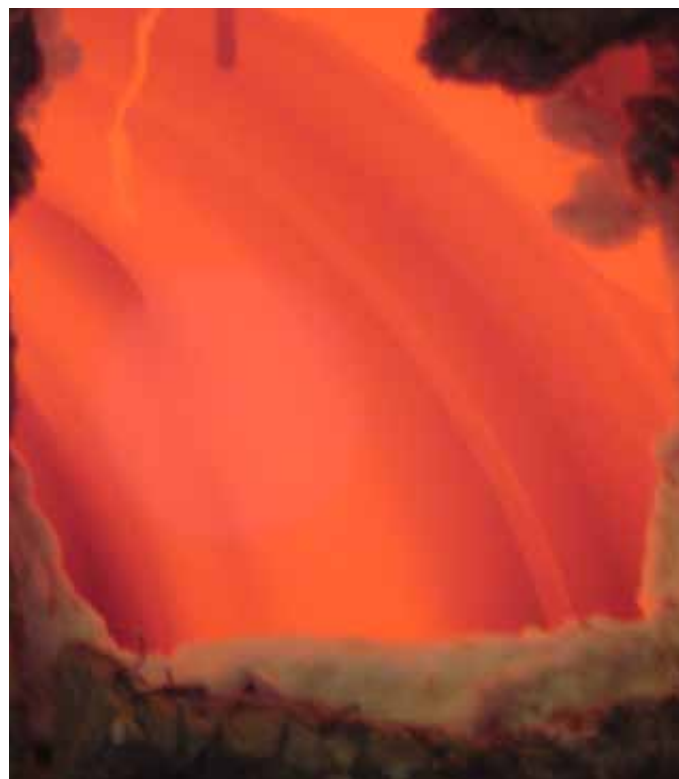

Firetest



Shipping



Expert staff members are our future

Many of the employees working for us today already started their apprenticeships in our company. One of the cornerstones of our corporate success is the training and further education of our own young talented employees.

We continually train young people in various technical and commercial professions. The German training system has clearly defined teaching and studying times with prescribed content and examinations in order to achieve this aim. At the end of the two-and-a-half or three-year training period the young people have gained comprehensive trade knowledge that enables them to work in their profession. We continually have around 20 trainees employed at the company.

Further training tailored to suit requirements

The systematic further training of our employees is a firm component of our quality management system in accordance with DIN EN ISO 9001. Each year we assess the training needs of each individual person and purposefully design our further training schedule accordingly. Thus we continually raise the general level of qualification within the company. One example of the success of these measures is that we continually have around 12 employees in the company who are qualified and certified to carry out and assess non-destructive testing procedures in accordance with DIN EN 473.



Training department has its own 5-axis sector CNC machine

Our trainees are introduced to both classical and modern production methods at an early stage. Young people can only develop to become competent experts if they are given sufficient time and space to learn. We have our own special training department to make sure they can do so properly. The department has every piece of equipment necessary for a well-founded training from a simple vice to a 5-axis CNC machine tool.



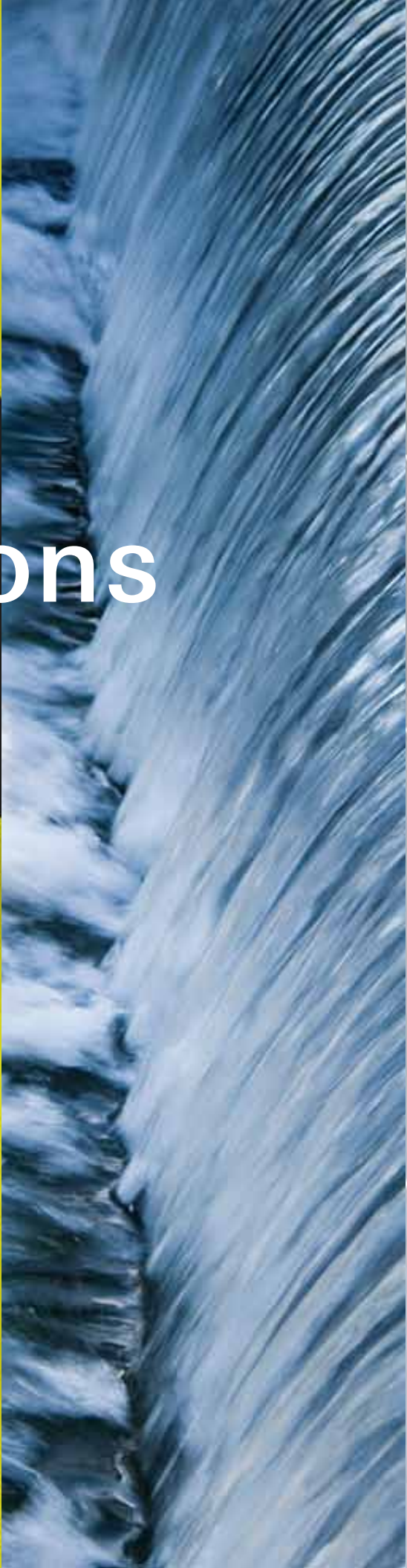

The applications

Ranges of application	Tight shut-off, throttle and control valves						Check valves					Combined tight shut-off, throttle and check valves		
	HTK	MAK	OSK	WAK	DSK ASK	NSK	RZN	RZI	FCV SCV	GMZ	MAG	GBZ	AZI	GZA
Power plant construction	•	•	•	•	•	•	•	•	•		•	•	•	•
Nuclear	•	•	•	•	•	•	•	•	•		•	•	•	•
Fossil-fired	•	•	•	•	•		•	•	•		•	•	•	•
Geothermal		•		•	•									
Hydroelectric		•	•											•
District heating industry		•			•		•	•			•	•	•	
Generation		•			•		•	•			•	•	•	
Pump station		•			•		•	•			•	•	•	
Gas industry	•	•	•	•	•					•	•			
Water/wastewater		•	•	•			•	•				•	•	•
Oil industry		•	•	•			•	•						
Onshore/offshore engineering		•	•	•			•	•				•	•	
Petrochemicals	•	•	•	•	•		•	•		•	•	•	•	
Ethylene plants	•	•									•			
Refineries	•	•	•	•	•		•	•		•	•	•	•	
Energy recovery	•	•		•	•									
Metallurgy		•	•	•	•		•	•		•	•			
Plant engineering	•	•	•	•	•		•	•		•	•	•	•	•
Seawater desalination		•	•	•			•	•				•	•	•
LNG/LPG		•												
Industrial plants	•	•	•	•	•		•	•		•	•	•	•	
Sugar industry		•		•							•			
Paper industry		•		•							•			

Special products	Spherical valves	Hollow-jet valves
Power plant construction		
Hydroelectric	•	•



Your requirements – our solution

We offer our customers decades of experience with products in various applications worldwide, combined with proven development and production expertise. In a nutshell: reliable solutions for your requirements.

Every customer application has its own very special requirements – no two power plants and no two refineries are the same. For this reason we continually develop tailor-made designs for our customers. In many cases they consist of minor changes to details of valves, but sometimes designs also need to be developed from scratch. However, all of our solutions have one thing in common: our customers can be absolutely sure that the finished products are ideally suited to their requirements. Thus the application and product overview on the left simply serves as a guide for possible uses. We will be happy to discuss solutions for further ranges of application individually with you.

Fossil-fired power plants

Nuclear power plants

Hydroelectric power plants

District heating

Gas industry /LNG

Oil industry / petrochemicals industry /
FCC / ethylene

Fossil-fired power plants

Reliable control for steam, condensate and water

Our extensive experience in the use of valves in fossil-fired power plants enables us to provide our customers with perfectly coordinated valve solutions for the various types of application within the power plant.

Our products are tried and tested over many years for various areas of application including pump protection for cooling water circuits, switchover valves, control valves and steam check valves for protecting turbines. Particularly when it comes to protecting turbines, the fast and therefore effective cutting out of the reverse current of steam or condensate is of the utmost importance. The flow of steam can reverse within 0.2 seconds, thereby causing considerable damage to the turbine. Depending on the model, our safety valves shut off completely within 0.2 seconds.

ADAMS valves are used in the following areas of power plants:

- Cooling water circuits
- Water input and water use
- Preheaters
- Vaporisers
- Fresh water
- For turbines and their protection

Valves used in fossil-fired power plants

- Steam check valves:
FCV, SCV, MAG-S
- Switchover- and control valves:
DSK, ASK
- Tight shut-off valves:
MAK, OSK, HTK
- Condensate-stop valves:
ASK, MAK
- Vacuum-breaking valves:
WAK
- Pump protection
(condensate and cooling water service):
AZI, GBZ, OSK, GZA
- Turbine protection valves:
DSK

Nuclear power plants

Safety has top priority

Valves for nuclear power plants are mostly highly specialised customer-made designs and their extraordinary characteristics are an expression of our expertise in development.

The fundamental areas of application for our valves in nuclear power plants are identical with those of fossil-fired power plants. However, due to the extraordinarily high degree of safety required for nuclear power plant applications, redesigned custom-made parts and in some cases completely newly developed valves are used. For many years we have been developing these solutions in cooperation with our customers to satisfy the requirements of each individual type of power plant. We were presented with the "Supplier Award" by our customer Siemens AG for developing valves for the Olkiluoto nuclear power plant in Finland.

ADAMS valves are used in the following areas of power plants:

- Cooling water circuits
- Water input and water use
- Preheaters
- Vaporisers
- Fresh water
- For turbines and their protection

Valves used in nuclear power plants

- Steam check valves:
FCV, SCV, MAG-S
- Switchover- and control valves:
DSK, ASK
- Tight shut-off valves:
MAK, OSK, HTK
- Condensate-stop valves:
ASK, MAK
- Vacuum-breaking valves:
WAK
- Pump protection
(condensate and cooling water service):
AZI, GBZ, OSK, GZA, RZN
- Turbine protection valves:
NSK



Hydroelectric power plants

Making natural power safe to use

Since time immemorial, mankind has harnessed the power of water. Today we have the ability to generate vast amounts of energy with this power. ADAMS SCHWEIZ AG, our waterpower expertise centre, offers a range of check valves and stop valves specially developed for this purpose.

Waterpower has two main advantages: firstly, it is continually available for generating energy and secondly, it can be stored – in reservoirs or artificial lakes, for example. However, the use of this potential is dependent on having a reliable hydroelectric power plant. From the point of view of valve engineering, this not only includes suitable turbine and pipe-rupture protection valves, but also, for example, environmentally oriented outlet valves, which also enrich the water with oxygen at the same time. Whether new construction or retrofitting: depending on the type of power plant, we develop individually designed complete solutions (e.g. inlet pipe, valve, pipe spool, outlet pipe, bypass) that optimally suit the requirements of our customers.

ADAMS components used in hydroelectric power plants

- Pipe-rupture safety valves
- Turbine protection valves
- Outlet valves
- Needle valves and plunger valves for bypasses
- Spherical valves
- Hollow-jet valves
- Aerating and venting valves
- Overspeed detectors



District heating

Renaissance of heating from networks

Changing attitudes in society with regard to energy supply are lending new attractiveness to the district heating networks of today. Our decades of experience in working with the district heating industry enable us to provide mature valve engineering for this range of applications.

We have worked closely with the district heating industry since 1962. This extensive experience enables us to provide tried-and-tested valve solutions for shutting off, controlling flow and protecting pumps. For example, we have been providing metallic sealing systems for decades for design/construction temperatures over 120 °C or if tightness is required on both sides.

We also provide valves for the district heating industry that are equipped with an individually adjustable damping system. We thus guarantee optimal control over the development of pressure surges, particularly in pipes with large diameters.

Valves used in district heating networks

- Stop valves:
MAK, DSK, ASK
- Check valves:
RZN, RZI
- Combined stop and check valves:
GBZ, AZI

Gas industry / LNG

LNG: switching at $-196\text{ }^{\circ}\text{C}$ without problems

For more than 20 years we have developed, produced and tested valves for use at extremely low temperatures. During this time we have continually expanded our expertise and in 2005 we installed an additional cryogenic test facility (7.30 x 26 metres) for large-scale valves.

Our valves are often used in the gas industry for controlling liquid gas applications (LNG). These include, for instance, gas liquefaction plants, LNG terminals and LNG storage tanks. We carry out extensive function and tightness tests in accordance with international standards and specifications to ensure that our valves always function reliably, even at extremely low temperatures.

Valves used for LNG and Gas industry

- LNG:
MAK, MAK Butt Weld Ends, MAK Side Entry
- Gas industry:
HTK, MAK, OSK, WAK, DSK / ASK, GMZ, MAG

Other types on request



Low temperature test

Oil industry / petrochemicals industry / FCC / ethylene

Enduring reliability in critical processes

Our valves have been reliably used for decades in refineries, FCC plants or tank farms as well as ethylene plants.

The long-term reliability of our products is the most important feature when it comes to their use in refineries. This is particularly the case as it is not only important to ensure reliable processes and protect the equipment; their foremost task is to protect people and the environment. When it comes to their application in the processing of crude oil, our valves are often required to meet a demanding combination of requirements: they must be just as capable of dealing with high temperatures as they are with high pressures and erosion caused by extremely abrasive media. The protecting of a turbo expander, for example, is performed with the help of extremely fast closing and opening times in the range of tenths of a second. Our valves guarantee these capabilities both enduringly and reliably.

Our triple-eccentric valve technology provides our customers with a high degree of safety in ethylene plants. Our valves are perfectly designed to perform their tasks: for example with a steam injection to prevent the build-up of coke on the seat of the seal, or with a feature that protects the valve seal from coke particles in the flowing medium. Various surface hardness coatings in the bearing and seat area increase the service life of valves in these critical applications.

Valves used in the oil industry, petrochemicals industry, FCC plants and ethylene plants

- Refineries:
HTK, MAK, OSK, WAK, DSK, ASK
RZN, RZI, GMZ, MAG
GBZ, AZI
- FCC:
HTK, ASK, DSK
- Ethylene plants:
HTK, MAK, MAG





The products

Valves for special requirements

High functional reliability under difficult operating conditions is one of the most important requirements for nearly all of our customers. As operating conditions can be highly individual, the majority of our valves are tailor-made to ensure they ideally meet customers' needs.

For over 50 years our company name has been synonymous with butterfly valves. Since the patenting of the triple-eccentric valve in 1960 we have continued to enhance and improve both these and the double-eccentric valves for numerous sophisticated ranges of application. The design features outstanding performance combined with comparatively low weight. This makes the valves particularly efficient.

Flexibility is our strength

We offer a comprehensive range of tight shut-off, throttle and valves as well as check valves and combinations of both systems. The constructing of tailor-made solutions to fulfil special customer wishes is part of our daily business. We often develop valves together with our customers – completely in line with their specific requirements and wishes.

We manufacture our products in a wide variety of materials. Both the selection and the combination of materials are based on many years of experience in the use of our valves in a broad range of applications worldwide. We also use varying types of sealing system; either soft sealing or metallic sealing, depending on the requirement. In addition, our customers have the choice between various seal seats or options such as a seal protector, which is used, for example, when abrasive media are worked with. Our valves are designed in accordance with international standards.



Tight shut-off, throttle and control valves

MAK	Page 52
HTK	Page 56
OSK	Page 58
WAK	Page 59
DSK	Page 60
ASK	Page 60
NSK	Page 62



Check valves

SCV	Page 66
FCV	Page 67
MAG	Page 68
GMZ	Page 68
RZN	Page 70
RZI	Page 70



Combined tight shut-off, throttle and check valves

GBZ	Page 72
AZI	Page 72
GZA	Page 73



Special products for hydroelectric power plants

Page 74

MAK



Tight shut-off valve MAK

Mature technology for a broad range of applications

Our MAK valves are universally utilisable products with triple-eccentric valve technology, suitable for extreme operating conditions and a high number of actuations. This type of valve has been successfully used since the 70s and is the further developed version of the original Adams patent.

Our MAK valves are so outstanding due to their high degree of reliability. This type of valve has proven its worth in a wide range of applications over decades. This not only means that we have been using the MAK with great success worldwide for almost 40 years, it also means that quite a number of customers are using valves we supplied decades ago, which are still in good working order in their plants. That is reliability.

One-hundred-per-cent tightness

We have remained true to the basic principle of the triple-eccentric design, which enables the valve to close one-hundred-per-cent tight. Despite this, we have continued enhancing details of this design over the years. For example, the MAK is equipped with a seal in the valve body. This protects the seal from the flowing medium, making maintenance intervals longer and increasing its service life. The special design of the seal enables the valve to be opened and closed without friction, even when working under great differences in temperature and full nominal pressure.

Range of applications

The MAK can be used for a broad range of temperatures and pressures. The MAK has proven to be highly efficient under conditions such as:

- Steam
- High temperature
- Low temperature
- High medium flow speeds
- High pressures
- Aggressive media
- Abrasive media

Types

The MAK is available either as a cast or a welded design with flange or butt-welded ends. The welded designs can be implemented in all commonly used materials. We also supply the MAK as a version with homogeneous double disc, between which it is possible, for example to achieve pressurisation. Depending on customers' requirements, we adapt the valves to suit special needs and also equip them with additional options. That is how a custom-made valve comes into being. That is one of our strengths.

A summary of the benefits:

- Tightness on both sides
- Low-friction function
- High resilience to temperatures
- Fireproof design
- Low actuation torques
- Excellent control characteristics
- Minimal pressure losses
- Compact, robust design
- Simple to maintain, even on site / replaceable interior parts
- Optional installation length
- Protection against emission
- "TA Luft" specification

Facts & Figures

NPS

DN 80 / 3 inches to DN 2400 / 96 inches
Further nominal widths on request

Temperature range

-196 °C / -320 °F to 600 °C / 1112 °F

Pressure Class

PN 10/16/25/40/64/100
ANSI 150/300/600/900/1500

Construction lengths in accordance with

ISO 5752 BS 13 (F16)
ISO 5752 BS 14 (F4)
ASME B 16.10, API 609

Valves designed in accordance with international standards, e. g.

AD technical instructions, ANSI, API, ASME, ATEX, BS, DGRL, DIN EN / ISO, GOST, KTA, MSS, NACE, RCC-M

Operation

Manual, pneumatic, electric, hydraulic

MAK

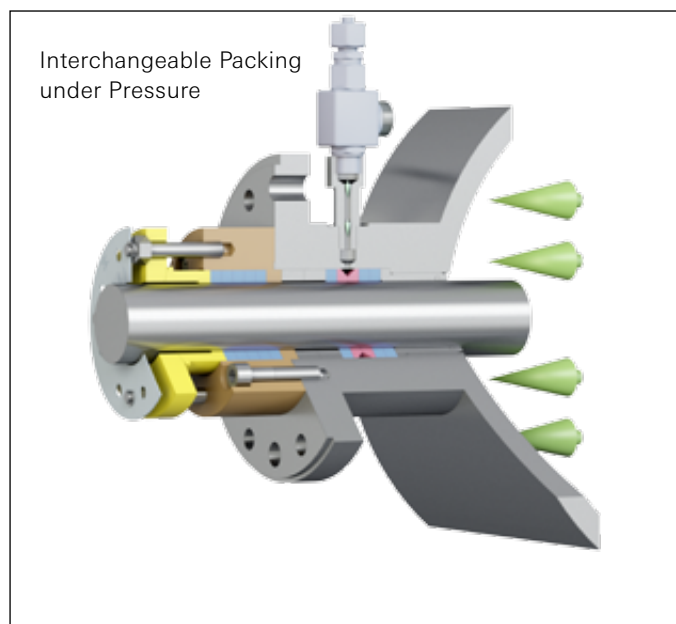

Security Stuffing Box

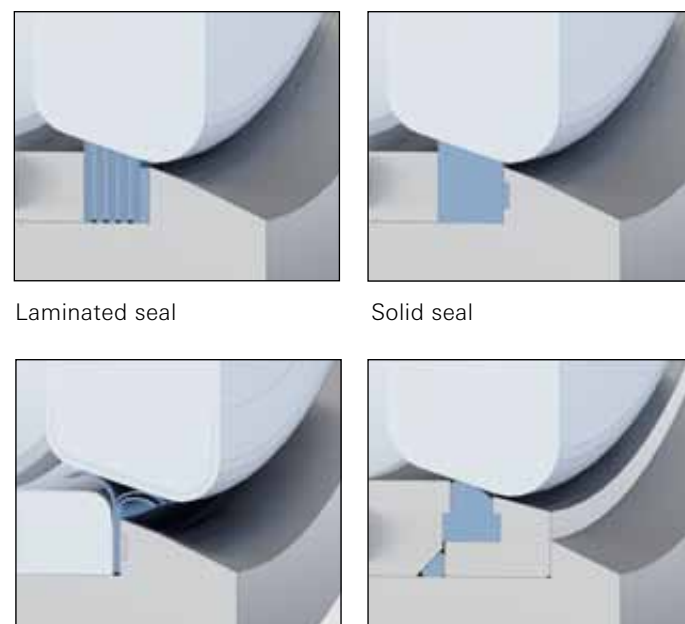

Laminated seal

Solid seal

L2 metal seal

Soft seal

Sealing systems

The sealing system integrated in the contour of the body was developed by Adams and is available with a metal-graphite laminated seal, a solid metallic seal, an L2 metal seal or a rubber seal. The advantages of these sealing systems are extremely reliable tightness, even in critical areas of application.



Live Loaded Packing and Lantern Ring

Packing

Depending on the type of application, various types of packing ensure optimum tightness for the requirements of the shaft system. For our customers we implement emission-proof packing with "TA Luft" specification.



Low-temperature applications

We have been successfully manufacturing valves for use at low temperatures since the 80s. The combination of selected materials, innovative engineering and high-quality manufacturing result in functional reliability even at a temperature of $-196\text{ }^{\circ}\text{C}$ and high pressure demands. With the help of our in-house testing facilities for low-temperature applications we continually develop our products to meet specialised customer requirements. This strategy enables us to react quickly and reliably to the individual wishes of our customers.

We use the following materials for low-temperature applications: CF8M, CF3M, CF8, CF3.



Blocking

We offer a blocking system as an additional safety feature for maintenance work. This guarantees the safe closing of the valve even in the highly unlikely event of a shaft breaking. This is demanded in many cases by safety authorities.

HTK

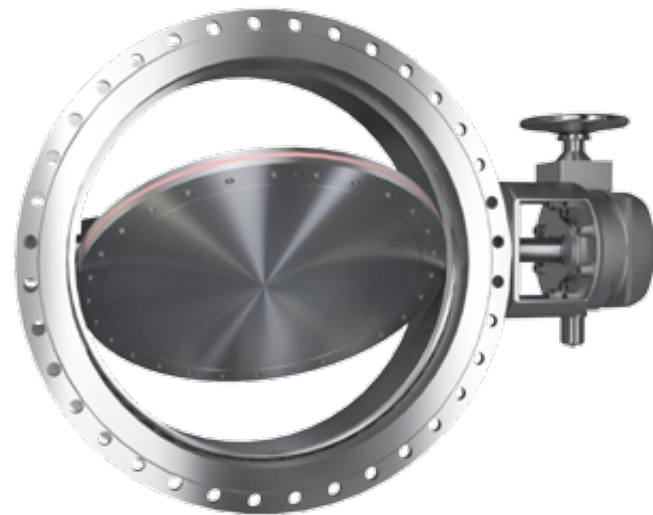

Tight shut-off valve HTK

Reliability at high temperatures and large nominal widths

The strength of HTK valves is their absolute tightness at temperatures up to 950 °C. The triple eccentricity combined with the special metallic sealing system in the valve ensures easy opening and closing, even at extreme temperatures.

Our state-of-the-art welding technology makes it possible to work with large nominal widths and enables us a great deal of flexibility with which we manufacture special lengths and custom-made valves in accordance with the requirements of our customers. Whether a heating jacket, single- or double-row steam injection, or valves that open and close at extremely high speeds: we provide customised solutions for the HTK for a wide variety of purposes. The compact design of the valve, even for large nominal widths, makes the HTK the valve of choice for both underground and overhead lines.

Types

The HTK is available both as a standard model and in a variety of customised designs. The custom-made models include:

- The HTK for ethylene plants
The TLV transferline valve and the DV decoking valve
- The HTK block & bleed
Two seals are placed one behind the other in the seal seat. A chamber between the seals can be used to suction off residual leakages or for barrier media.
- HTK for FCC plants
Valves with expander inlet and bypass for coping with extremely high temperatures and abrasive media.

A summary of the benefits

- Optimal tightness
- Withstands high temperatures
- Progressive sealing
- Reliable functioning in any position installed
- Capable of combining various operating tasks: flow regulation, shut-off function
- Great resilience, even at high switching frequency
- High flexibility due to welded construction

Block & bleed

Operating processes can make it necessary to avoid even the most minor of leakages. In order to achieve this, two seals are placed one behind the other in the seal seat with a chamber between them. The chamber can be pressurised with a barrier medium of liquid or gas. A leakage detector can also be installed to test tightness.

Quick-opening and quick-closing function

The control and regulation of opening and closing can be supplemented with a quick-opening and quick-closing function. The function offers control reaction times of less than one second.

Hard-coated seal seat

For use at extremely high temperatures, solid metal seals are used that are additionally hard-coated. The sealing parts both on the valve and in the body are equipped with a low-wear hard facing.

Facts & Figures

NPS

DN 150 / 6 inches to DN 4000 / 160 inches

Temperature range

-196 °C / -320 °F to 950 °C / 1.742 °F

Pressure Class

PN 10/16/25/40

ANSI 150/300/600/900/1500

Construction lengths in accordance with

ISO 5752 BS 13 (F16)

ISO 5752 BS 14 (F4)

ASME B 16.10, API 609

Custom-made construction lengths on request

Valves designed in accordance with international standards, e. g.

AD technical instructions, ANSI, API, ASME, ATEX, BS, DGRL, DIN EN / ISO, GOST, KTA, MSS, NACE, RCC-M

Operation

Manual, pneumatic, electric, hydraulic

OSK



Tight shut-off valve OSK

Economy in large dimensions

Our OSK valve offers an economical solution, for instance for piping systems conveying liquids or gases. Its compact design and flexible welded construction make it suitable for a wide range of applications.

The OSK's double-eccentrically positioned valve disc and the hydrodynamically optimised soft sealing system allow the medium to flow through homogeneously without dead zones. Low wear is guaranteed by two factors: the continuous valve seal is highly resistant to hydrodynamic forces and low friction is gentle on the sealing system. Furthermore, rubber-coated valves or those made of stainless materials are available to ensure resistance to corrosion. A seawater model is also available.

Types

The OSK can be adapted to suit special requirements with a number of options:

- L1 metal seal
- Blocking system
- Vulcanised hard rubber lining
- Butt-welded version
- Elements for remote transmission

A summary of the benefits

- Double-eccentric positioning of the valve stem
- Gas-proof closure
- Compact design
- Low weight
- Low actuation torques
- Good control characteristics

Facts & Figures

NPS

DN 150 / 8 inches to DN 4200 / 168 inches

Temperature range

-50 °C / -58 °F up to 150 °C / 302 °F

Pressure Class

PN 2.5/6/10/16/25/40/64
ANSI 150/300/400

Construction lengths in accordance with

ISO 5752 BS 13 (F16)
ISO 5752 BS 14 (F4)
ASME B 16.10, API 609
Custom-made construction lengths on request

Valves designed in accordance with international standards, e. g.

AD technical instructions, ANSI, API, ASME, ATEX, BS, DGRL, DIN EN / ISO, GOST, KTA, MSS, NACE, RCC-M

Operation

Manual, electric, pneumatic, hydraulic

WAK

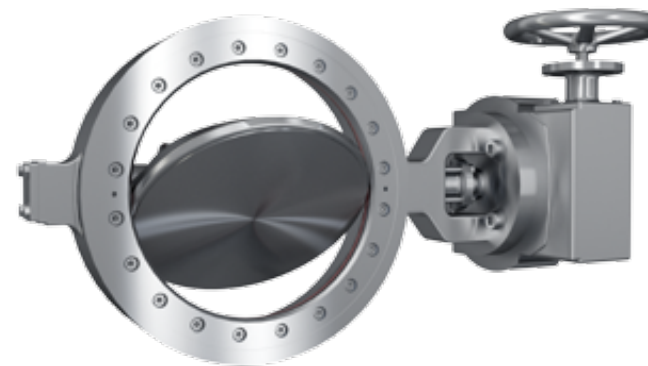

Tight shut-off valve WAK

Lug and wafer valves for HPBV replacement

The WAK has a wide range of uses due to its low-cost construction as a lug and wafer design.

Its sealing system is incorporated in the body and guarantees low-friction opening and closing without jamming. The metal seal ensures tightness on one side and is designed to withstand high temperatures.

The WAK features first-class control characteristics and very low pressure losses. The hydrodynamically optimised, low-cost valve is used in a great many applications, particularly in compressor and pump lines.

Types

The WAK is available in a variety of models, such as:

- Fire-safe model
- Single flange model
- With tapped and through-holes (lug type)

A summary of the benefits

- Low torques
- Compact design
- Low weight
- Any installation position
- Good control characteristics
- Wide range of applications

Facts & Figures

NPS

DN 80 / 3 inches up to DN 1200 / 48 inches

Temperature range

-20 °C / -4 °F up to 150 °C / 302 °F (soft seal)
-50 °C / -58 °F up to 500 °C / 932 °F (metal seal)

Pressure Class

ANSI 150/300

Construction lengths in accordance with

API 609

Valves designed in accordance with international standards, e. g.

ANSI, API, ASNE, MSS, NACE

Operation

Manual, electric, pneumatic, hydraulic

DSK/ASK

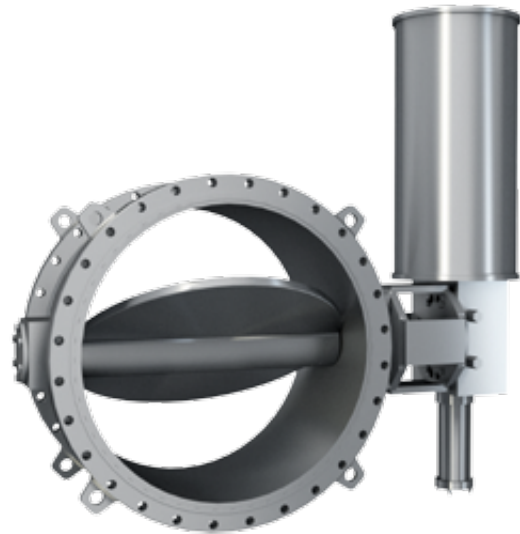

Throttle valve DSK

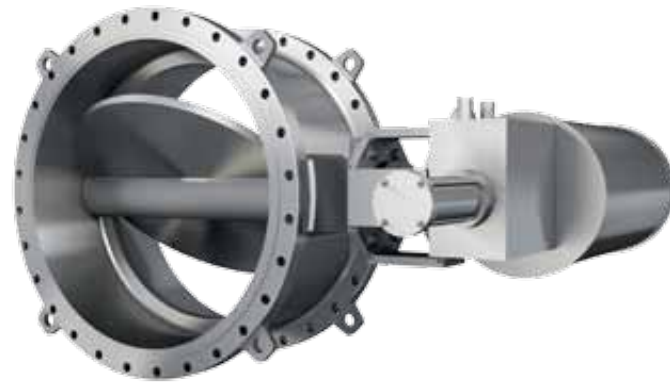

Throttle valve ASK

Precise flow control

Our proven DSK and ASK throttle valves are based on a technically mature, economical steel construction. Thanks to their precise flow control and low actuation torques, these valves are ideally suited for both gaseous and liquid media.

The throttle valves are fitted with electric, pneumatic or hydraulic controls, depending on requirements. Their welded construction makes the valves flexible and they can be ideally adapted to suit customers' requirements with regard to flow as well as additional parameters. The convincing control behaviour of the valve is determined by the given proportionality of the regulation. In addition, the valves are hydrodynamically optimised in design and therefore cause only minimal pressure losses.

Types DSK/ASK for steam or gas turbines

The DSK is a throttle valve with a swing through disc, which is mainly used in steam turbines.

The ASK is fitted with a step seated valve disc and is mainly used for gas turbines.

Both types are equipped with position controllers when used in control circuits. Selsyn transmitters and end switches are built in for remote transmission.

Other available options include:

- Heating jacket
- Temperature-resistant body lining
- Vulcanised hard rubber lining
- Live-loaded packing
- Low-emission stem sealing (TA Luft*)
- Emergency hand wheel
- Wafer design
- Butt-welded version

A summary of the benefits

- Precise flow control
- Low actuation torques
- Simple to maintain, even on site
- Low-cost steel welded construction

Facts & Figures

NPS

DN 100 / 4 inches up to DN 4000 / 160 inches

Temperature range

-50 °C / -58 °F to 950 °C / 1,742 °F

Pressure Class

PN 6/10/16/25/40/64/100

ANSI 150/300/600

Construction lengths in accordance with

ISO 5752 BS 13 (F16)

ISO 5752 BS 14 (F4)

ASME B 16.10, API 609

Custom-made construction lengths on request

Valves designed in accordance with international standards, e. g.

AD technical instructions, ANSI, API, ASME, ATEX, BS, DGRL, DIN EN / ISO, GOST, KTA, MSS, NACE, RCC-M

Operation

Electric, pneumatic, hydraulic

NSK



Quick-closing and control valve NSK

For absolute safety in nuclear power plants

Our NSK valve was specially developed for safeguarding turbines in nuclear power plants: a hydraulically actuated quick-closing and control valve that more than meets the increased safety requirements of a nuclear power plant.

The NSK is located downstream from the reheater in order to protect the low-pressure turbines. Depending on the design of the power plant, we plan and develop an ideal solution together with our customers. Thus, these valves are installed at the Olkiluoto 3 nuclear power plant in Finland. A specially segmented sealing system with an intermediate steam exhaust system guarantees, that the stems are reliably sealed. We were presented with the "Supplier Award" by our customer Siemens AG for developing the valves used at the Olkiluoto nuclear power plant in Finland.

A summary of the benefits

- Robust body design
- Two valve discs in one body (therefore fewer welds on the body and fewer regular examinations necessary)
- Hydrodynamically optimised design with spherically formed valve discs
- Valve discs eccentrically positioned with self-closing behaviour
- Body with mechanical end stops to avoid the impact of vibrations
- Bearing and valve stem CDS-coated
- Secured drainage of the bearings
- Stem sealing through automatically adjusting tubular spring sealing with sealing steam connection and waste steam exhaust extraction
- Automatic closure in case of auxiliary power failure
- Valve stem located in valve disc
- Cardan connection of the drive via steel lamination coupling
- Hydraulic drive with secured closed position via disc spring assemblies

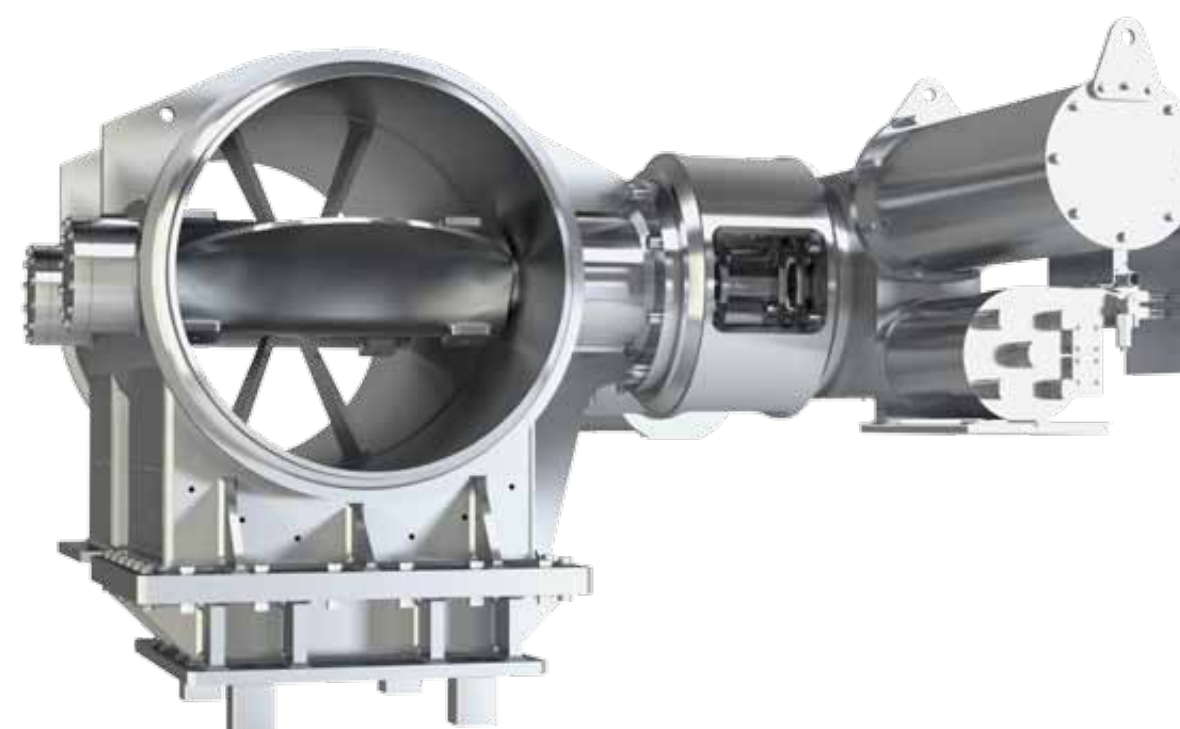
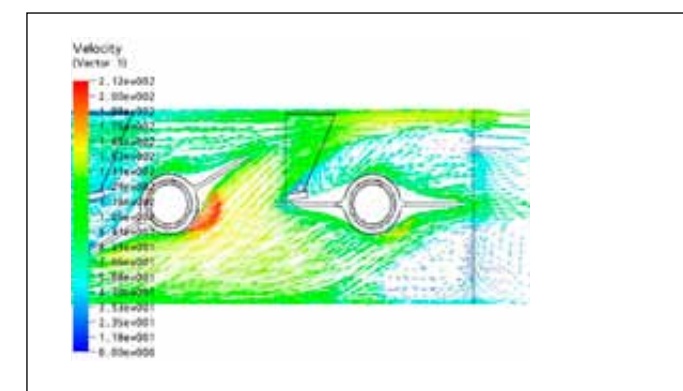
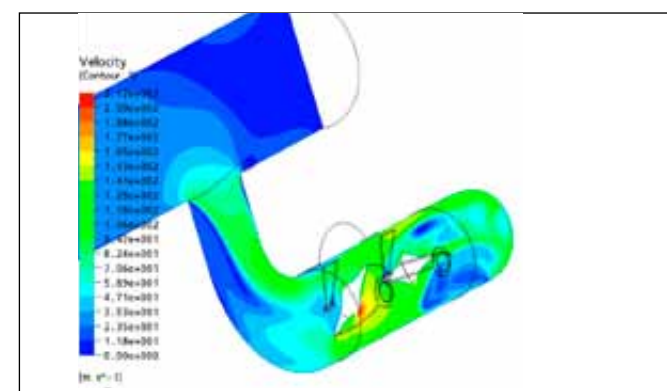
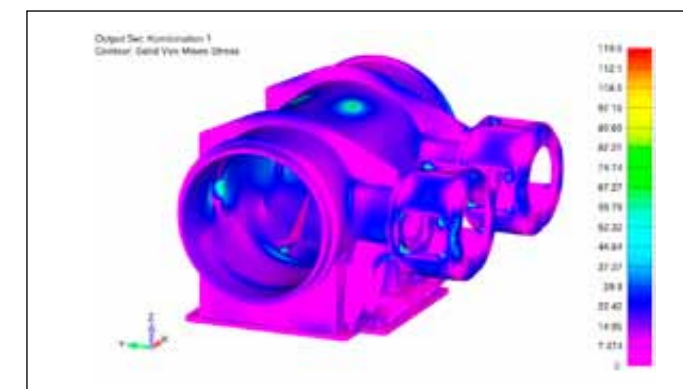
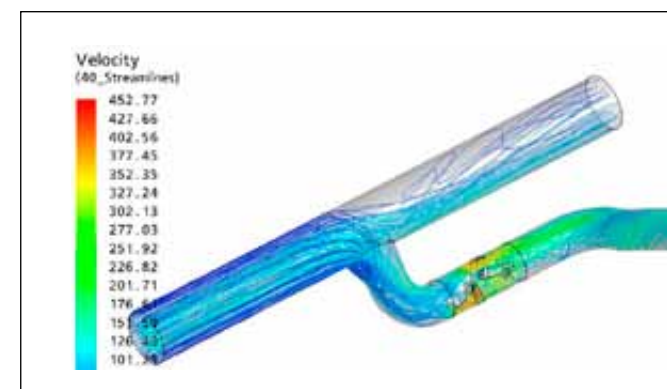

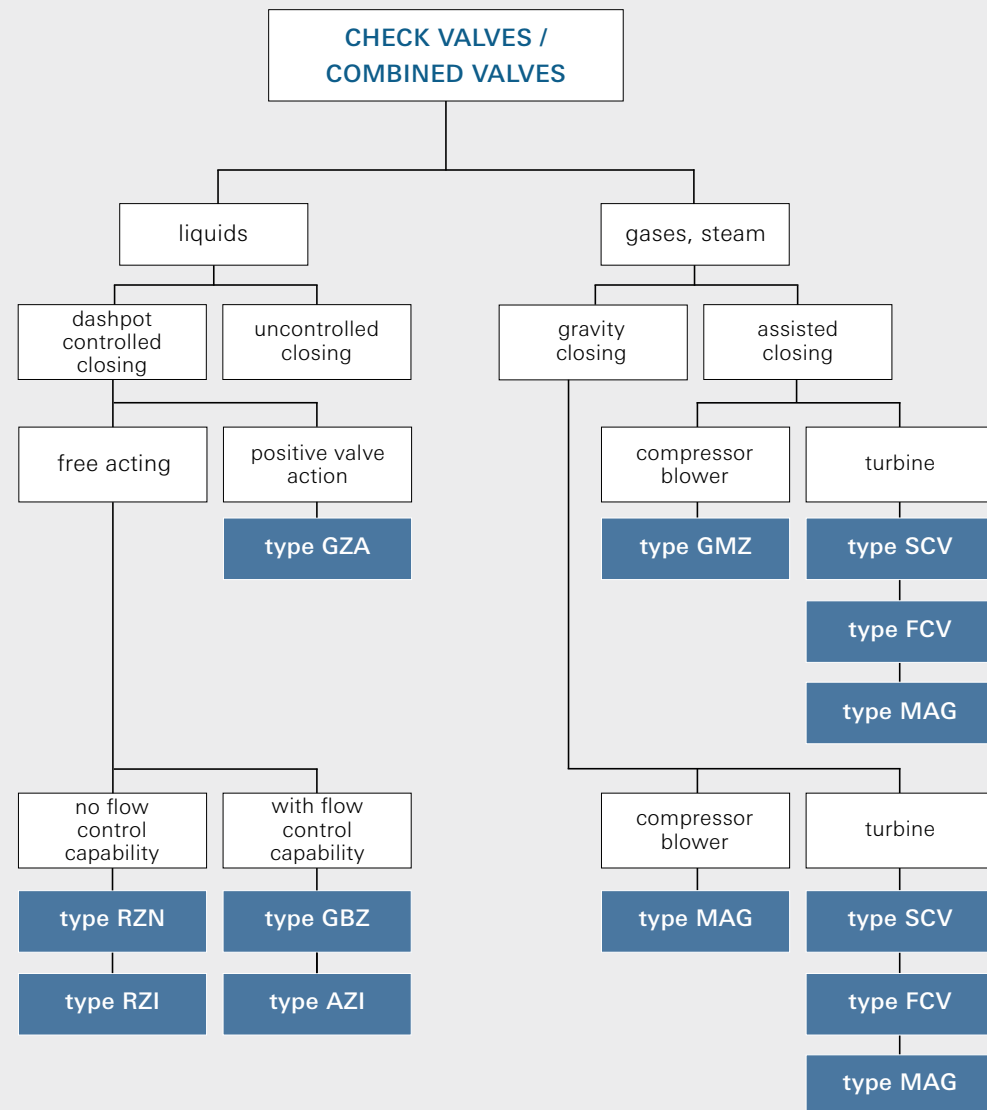

The right choice

Check valves are essential safety features in a great number of industrial plants. Depending on the application, it is their task to protect people, the environment or the value of the plant.

State-of-the-art industrial plants often place high demands on the valves used; for example, in many processes they are subject to extremely high temperatures, high pressures or aggressive media. In view of these facts, the selection of the right check valve is crucial for the optimal safeguarding of the plant. The following overview provides an initial impression of criteria for selecting check valves. Please feel free to speak to us about arranging a detailed consultation concerning your particular needs.

The type of medium

The foremost selection criterion is the question of the type of medium. Is it liquid, gas or steam? The inertia and viscosity of the medium are the main factors determining the characteristics of the valve. Equally important is the time the flow of the medium can take to reverse behind a turbine or pump. In certain applications, e.g. in the case of gas, this can happen within 0.2 seconds, in which time the valve must react as a protective feature.

Liquid media

In the case of liquid media the closure characteristics are then considered, as the valve must be dampened and close in a controlled way in order to avoid the danger of water hammer. Water hammer occurs when a valve that closes without being dampened is quickly pressed into its seat by the reverse flow of the medium when the pump is switched off. This causes a shock wave that can cause damage to the entire system.

Free-swinging or controlled

In a great number of applications the check valve is set up to swing freely, i.e. it opens when the medium flows without outside control and closes in reverse flow situations, e.g. in order to protect pumps. The valve is balanced in such a way that it is forced open by the media flow as desired. It then closes again when the media flow decreases. However, the free-swinging valves can be blocked in determined positions in order to control the flow of media by means of an overrunning clutch. The overrunning clutch makes it possible to block in the flow direction, whereas the valve still closes when the pressure drops.

Gas and steam

In the case of gas and steam systems, the first selection criterion is initially the question of whether a counterweight is sufficient for the closure system or whether a closure drive needs to be used. Closure drives have the advantage of making it possible to close the valve extremely quickly. Furthermore, they can be connected to external control systems.

SCV



A summary of the benefits

- Tightness at least in accordance with ANSI/FCI 70-2 Cl. V
- No jamming at seat
- Low pressure loss due to overrunning clutch
- High resilience to temperatures
- Fireproof design
- Low drive torque
- Compact, robust design
- Minimal maintenance; on-site maintenance possible
- Inspection and assembly opening

The valve disc made of chrome steel reduces abrasions. The valve discs of installed valves can be replaced via the inspection and assembly opening. The seal seat is manufactured by deposit welding and can be hard-coated if necessary.

Check valve SCV

Ideal protection from backflows for steam turbines

Extremely reliable check valves are needed to protect steam and gas turbines from reverse flows. With their reliable, non-jamming closures, our SCV valves are optimally designed to fulfil this important protective function.

SCV check valves efficiently protect steam and gas turbines from backflows coming from steam extraction pipes. This is guaranteed by a free-swinging model that closes automatically by means of its own weight. This enables it to swing closed against a double bearing friction moment without the assistance of a drive system. This makes extremely short closure times of under 0.5 seconds possible. A hydraulic or pneumatic drive can be added as a closure aid by means of a two-part stem construction.

Types

The SCV is a robust cast valve with butt-welded ends. Welding neck flanges can be welded on.

Facts & Figures

NPS

150 mm / 6 inches up to 1050 / 42 inches

Temperature range

Steam up to 550 °C / 1,025 °F

Pressure Class

PN 10/16/25/40/64/100
ANSI 150/300/600/900

Construction lengths in accordance with DIN EN 558 table 8

Valves designed in accordance with international standards, e. g.

AD technical instructions, ANSI, API, ASME, ATEX, BS, DGRL, DIN EN / ISO, GOST, KTA, MSS, RCC-M

Operation

Self-closing, pneumatic, hydraulic

FCV



Check valve FCV

Safety in fractions of a second

FCV check valves protect large steam turbines and compactors when load shedding with flow reversal in fractions of seconds. The specially designed valve closes automatically and absorbs the occurring high dynamic forces.

Modern high-performance steam turbines are efficient but expensive continuous flow machines, which need to be protected from possible damage. The FCV check valve features high responsiveness and automatic closure through its own weight within a mere 0.3 seconds. This is achieved through low moments of inertia, the short closure distance and the triple-eccentric closure system with obliquely positioned sealing cones. Force-actuated closure is possible with pneumatic, hydraulic or spring-loaded closing drives.

Types

The FCV is equipped with a triple-eccentric shut-off system and is manufactured as a forged model. The seal seat and seal periphery are hard-coated.

An inspection opening, an internal steam heating and a drainage connection are available as well as elements for remote transmission. The FCV is also available as a flange model.

A summary of the benefits

- Robust forged steel construction
- Outstanding sealing characteristics at both high and low operating pressures
- Short closing distance
- Absorbs high dynamic forces
- No jamming at seat
- Low internal friction
- No internal bolted joints
- Minimal maintenance; also possible on site
- Absolute operating reliability at high closing frequencies

Facts & Figures

NPS

DN 100 / 4 inches up to DN 1200 / 48 inches

Temperature range

-196 °C / -320 °F up to 950 °C / 1,742 °F

Pressure Class

PN 16/25/40/64/100/160/250
ANSI 300/600/900/1500/2500

Construction lengths in accordance with ISO F 5 (butt-welded version)

Valves designed in accordance with international standards, e. g.

AD technical instructions, ANSI, API, ASME, ATEX, BS, DGRL, DIN EN / ISO, GOST, KTA, MSS, NACE, RCC-M

Operation

Self-closing, pneumatic, hydraulic

MAG/GMZ



Check valve MAG



Check valve GMZ

Safety when flows reverse

We specially developed the MAG and GMZ check valves in order to protect turbines and compressors in steam and gas lines from flow reversals. The sophisticated technology features very fast closing times and a low level of pressure loss.

MAG

The hallmark of the MAG is an external balancing weight that optimally counterbalances the valve disc. The advantage is that the valve is very responsive and the disc reliably reaches its final closing position. Due to the positioning of the balancing weight in its own pressure-resistant body without gland shaft seals, the valve exhibits low internal friction, which benefits the optimal closing and opening characteristics.

GMZ

Our GMZ check valves protect important continuous flow machines from the dangers of backflows. An extremely low degree of internal friction and a finely responsive adjustable counterweight enable the valve to react sensitively. The GMZ is additionally equipped with a pneumatic, spring-controlled drive, enabling controlled and rapid closing behaviour. It is also fitted with a hydraulic damping system to avoid any tendencies the valve disc has to vibrate during flow changes.

Range of applications for MAG/GMZ

As automatically closing check valves, MAG and GMZ are used in exhaust steam pipes in steam turbines as well as in pressure lines of compressors in air and gas systems. The valves can be fitted with either a hydraulic or pneumatic auxiliary drive with spring loading as additional closing support. An overrunning clutch (MAG) enables the free movement, which is not influenced by drive and gland shaft friction.

A summary of the benefits (MAG)

- Excellent tight shut-off behaviour
- Minimal pressure losses
- Additional screw retention
- Robust design
- Minimal maintenance cost

A summary of the benefits (GMZ)

- Positive closing behaviour via spring-loaded pneumatic operation
- Adjustable hydraulic damping facility
- Avoidance of tendencies of the valve disc to vibrate during operation
- Adjustability of slight pressure losses via the closure weight
- Additional screw retention
- High availability and long service life

Facts & Figures MAG

NPS

DN 150 / 6 inches up to DN 2000 / 80 inches

Temperature range

-50 °C / -58 °F up to 500 °C / 932 °F

Pressure Class

PN 6/10/16/25/40
ANSI 150/300

Construction lengths in accordance with

ISO 5752 BS 14 (F4)
Custom-made construction lengths on request

Valves designed in accordance with international standards, e. g.

AD technical instructions, ANSI, API, ASME, ATEX, BS, DGRL, DIN EN / ISO, GOST, KTA, MSS, NACE, RCC-M

Operation

Self-closing, pneumatic, hydraulic, electric

Facts & Figures GMZ

NPS

DN 150 / 6 inches up to DN 2000 / 80 inches

Temperature range

-50 °C / -58 °F up to 250 °C / 482 °F

Pressure Class

PN 2.5/6/10/16/25/40
ANSI 150/300

Construction lengths in accordance with

ISO 5752 BS 14 (F4)
Custom-made construction lengths on request

Valves designed in accordance with international standards, e. g.

AD technical instructions, ANSI, API, ASME, ATEX, BS, DGRL, DIN EN / ISO, GOST, KTA, MSS, NACE, RCC-M

Operation

Pneumatic

RZN/RZI

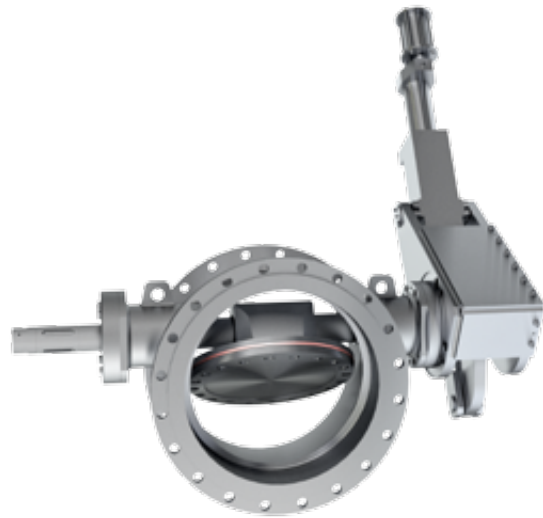

Check valve RZN



Check valve RZI

Complete pump protection in sophisticated areas

Our RZN and RZI check valves offer proven pump protection for applications with liquid media. The individually adjustable damping system enables the butterfly valve to perform shock-free checking, even in critical areas.

Our RZN and RZI butterfly valves feature first-class hydrodynamic characteristics, low pressure losses and the individually adaptable damping system. The closing characteristics of the butterfly valve can be optimally adjusted to suit the needs of each system with the help of the damping system. The RZN and RZI models can also be simply readjusted to adapt to new requirements if changes are made to the system at any point in the future.

Long service life

The compact design of the RZN check valve even makes it possible to operate in very limited spaces. The valve is robust and long lasting and can also be fitted with soft seals in a metallic seat or strip-metal seals for use at higher temperatures. Based on the same proven design, the RZI was developed for pipe dimensions over 1,000 millimetres. The damping system has been adapted to suit the greater forces.

Range of applications

The RZN and RZI check valves are ideally suited for protecting pumps for liquid media. The high flexibility of material and seal models enables the valves to be used in a wide variety of applications. For example, a seawater model is available in stainless steel and with a hard rubber lining.

A summary of the benefits

- Complete pump protection
- Controlled, shock-free closing
- Low pressure loss
- Progressive sealing
- Individually adjustable damping system
- Automatic mode of action
- Additional screw retention
- Subsequent installation of counterweight possible

Facts & Figures RZN

NPS

RZN: DN 150 / 6 inches up to DN 1000 m / 40 inches

Temperature range

-50 °C / -58 °F up to 200 °C / 392 °F

Pressure Class

PN 10/16/25/40/64
ANSI 150/300/600

Construction lengths in accordance with

ISO 5752 BS 14 (F4)

Custom-made construction lengths on request

Valves designed in accordance with international standards, e. g.

AD technical instructions, ANSI, API, ASME, ATEX, BS, DGRL, DIN EN / ISO, GOST, KTA, MSS, RCC-M

Operation

Automatically closing and adjustable hydraulically damped

Facts & Figures RZI

NPS

DN 500 / 20 inches up to DN 3000 / 120 inches

Temperature range

-50 °C / -58 °F up to 200 °C / 392 °F

Pressure Class

PN 2.5/6/10/16/25/40
ANSI 150/300

Construction lengths in accordance with

ISO 5752 BS 14 (F4)

Custom-made construction lengths on request

Valves designed in accordance with international standards, e. g.

AD technical instructions, ANSI, API, ASME, ATEX, BS, DGRL, DIN EN / ISO, GOST, KTA, MSS, RCC-M

Operation

Automatically closing and adjustable hydraulically damped

GBZ/AZI

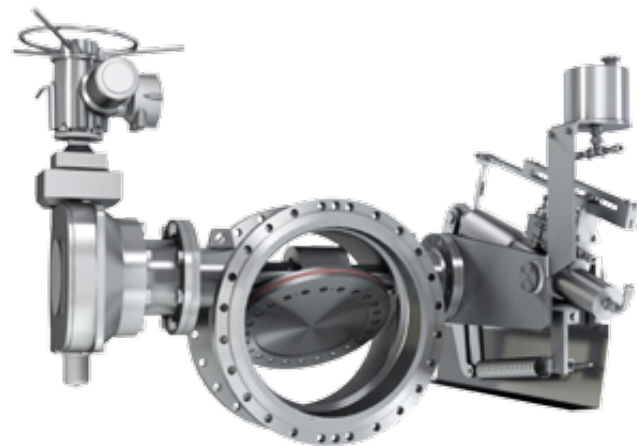

Tight shut-off, throttle and check valve AZI

A summary of the benefits

- Triple function: shut-off, throttling, checking
- Compact dimensions
- Lower loss of pressure (compared with using two valves)
- No flow turbulences
- Low-noise, controlled, shock-free closure
- Damping and braking system externally individually adjustable during operation
- Additional screw retention
- Prepared for subsequent installation of counterweight
- Can be retrofitted with electric positioning drive

Well combined

Our GBZ and AZI combination valves provide a particularly efficient solution: they combine tight shut-off, throttle and check valves in one single unit.

The GBZ and AZI combination valves are especially space-saving as their triple function replaces the two valves that would have otherwise been necessary – the check and shut-off elements. Its shut-off and control operations are achieved via an overrunning clutch. The advantage is that the hydraulically damped disc can move freely and closes automatically and shock-free if a pump fails. Therefore this type of valve is particularly reliable and economical. The GBZ and the AZI are equipped with a hydraulic damping system separate from the operating medium, externally fitted and multi-adjustable.

Facts & Figures

NPS

GBZ: DN 100 / 4 inches up to DN 800 / 32 inches
AZI: DN 500 / 20 inches up to DN 3000 / 120 inches

Temperature range

-50 °C / -58 °F up to 200 °C / 392 °F

Pressure Class

PN 2.5/6/10/16/25/40
ANSI 150/300

Construction lengths in accordance with ISO 5752 BS 14 (F4)

Custom-made construction lengths on request

Valves designed in accordance with international standards, e. g.

AD technical instructions, ANSI, API, ASME, ATEX, BS, DGRL, DIN EN / ISO, GOST, KTA, MSS, RCC-M

Operation

Manual, electric, adjustable hydraulically damped

GZA



Tight shut-off, throttle and check valve GZA

Reliability at large nominal widths

The GZA is a combined shut-off and check valve featuring a closure weight and hydraulic controls. The closure system works reliably, even in the event of a complete power failure.

Due to the large possible nominal widths up to DN 4.000, the GZA is often used in cooling water systems for power plants and for penstocks. Its range of applications includes pipe-rupture safety as well as pump and turbine protection. The GZA is manufactured either with massive disc or a bi-plane valve disc design.

A summary of the benefits

- Low pressure-loss coefficients
- Service-friendly construction
- Hydrodynamically designed valve disc
- Operation via an externally positioned closure weight and hydraulic service drive
- Custom-made models with a wide range of options

Facts & Figures

NPS

DN 500 / 20 inches up to DN 4000 / 160 inches

Temperature range

-20 °C / -4 °F up to 150 °C / 302 °F

Pressure Class

PN 2.5/6/10/16/25/40/64
ANSI 150/300

Construction lengths in accordance with

ISO 5752 BS 13 (F16)
ISO 5752 BS 14 (F4)
API 609

Custom-made construction lengths on request

Valves designed in accordance with international standards, e. g.

AD technical instructions, ANSI, API, ASME, ATEX, BS, DGRL, DIN EN / ISO, GOST, KTA, MSS, RCC-M

Operation

Hydraulic

HYDROELECTRIC



Stop- and throttle valve



Spherical valve

Comprehensive safety for hydroelectric power plants

The ADAMS hydroelectric power plant programme covers all areas of application. From pipe-rupture to turbine protection and the environmentally compatible outlet of water. In terms of safety our products offer absolute reliability and also guarantee tight closure in any demanding situation.

Stop- and throttle valves

Whether at the beginning of the pressure pipe for pipe-rupture protection or when it comes to protecting turbines from overrunning: our stop- and throttle valves are ideally suited for critical situations. The valves are welded in high-quality steel, the valve discs are hydrodynamically shaped to minimise pressure losses and the valve remains absolutely tight in all operating situations.

Spherical valves

At high operating pressures our spherical valves are recommended for use as safety and check valves. They are either welded or forged in high-quality steel. They close automatically by weight or flow. Their two sealing systems make it possible to carry out maintenance work without having to empty the pressure pipe.



Hollow-jet valve

Hollow-jet valves

Our hollow-jet valves have proved their high efficiency in hydroelectric power plants and irrigation dams. They ensure a regulated and environmentally compatible outlet of water either to the outside or into underwater tanks. The water is also enriched with oxygen at the same time. Their high-quality steel construction combined with elastic/metallic sealing enables energy dissipation without cavitation.

Accessories

depending on the requirements of the plant, ADAMS offers the matching accessories such as aerating and venting valves, overspeed detectors, bypasses, installation and extension pipes, plunger valves and needle valves.

Facts & Figures

NPS

Stop- and throttle valve
DN 200 / 8 inches up to DN 4200 / 168 inches
Spherical valve
DN 200 / 8 inches up to DN 2000 / 80 inches
Hollow-jet valves
DN 200 / 8 inches up to DN 3500 / 140 inches

Pressure Class

Stop- and throttle valve
PN 2 up to PN 30 / depending on the nominal width
Spherical valve
PN 20 up to PN 160 / depending on the nominal width
Hollow-jet valve
PN 2 up to PN 30 / depending on the nominal width

Valves designed in accordance with international standards, e. g.

DIN EN / ISO, ANSI, API, ASME, MSS, BS, AFNOR, GOST

Operation

Manual, pneumatic, electric, hydraulic (oil or water)

AMS
ARMATUREN

Manufacturer certification to directive 94/9/EG

Products were subject of a risk assessment in accordance with the ATEX Directive 94/9/EG (ATEX). The results of the assessment show that the products do not have potential for ignition under normal operating conditions. Therefore the products are not subject to the requirements of the ATEX Directive 94/9/EG and must not be marked as ATEX-compliant.

Additional electrical or mechanical components for potential explosion protection must be installed and tested separately. For integration, commissioning and instructions made in the IOM (Instruction Manual) have to be followed.

For specific media (not conductive) and applications, the manufacturer's instructions must be followed. According to directive 1992/90/EEC, in such cases the conduction of electricity is not allowed.

CERTIFICATE

The Certification Body for Pressure Equipment
of TÜV NORD Systems GmbH & Co. KG

certifies that the company

Adams Armaturen GmbH
Baukauer Str. 55
D-44653 Herne

has been verified and recognized
as welding workshop in the product range of

**tight shut-off valves, check valves, control valves
and combined valves**

based on the requirements of the standard

DIN EN ISO 3834-2 (EN 729-2)

Certificate-no.: 07-202-1403 EN 15

The range of validity and details of the inspection can be taken from the

Report-no.: 8106510950

The company is subject to regular audits by TÜV NORD

Confirmation according to nuclear standard KT 100

On behalf of the German EnBW Kernkraft GmbH, KKW Philippsburg, working group "Assessment of the qualification for system- and product reliability"

ADAMS Armaturen GmbH
Baukauerstr. 55,
D-44653 Herne

and the scope of supply and services

Construction/Engineering, Manufacturing, Installation, Maintenance, Repair, Overhaul, Testing, Commissioning, Start-up, Shut-down, Throttle Valves, Control Valves, Isolation Valves, Butterfly Valves, Check Valves, Shut-off Valves, Combined Valves

The assessment was performed by TÜV NORD Systems GmbH

Certificate No.: 10050/1

Lloyd's Register

CERTIFICATE
in accordance with the requirements of the Pressure Equipment Directive 97/23/EC

This is to certify that the Quality Assurance System of

Adams Armaturen GmbH
D-44653 Herne,
Germany

has been assessed by LRQA GmbH against the requirements of Annex B of the Pressure Equipment Directive 97/23/EC and conforms to the requirements for the products shown below:

MODUL H and H1

Industrial valves of following types:
HTK, MAK, HPV, OSK, WAK, DSK, ASK, RZN, RZI, FCV, SCV, GMZ, MAG, GBZ, AZI und GZA.

Approval is subject to the continued maintenance of the quality system in accordance with the requirements of the above mentioned Directive.

Authorisation is hereby given to use the under noted LRC Notified Body Identification Number in accordance with the requirements of the Pressure Equipment Directive in relation to the products as identified below.

CE 0525

Initial Approval:

Certificate Expiry Date:

LRQA GmbH Ident-No. 0525

CERTIFICATE

The Certification Body for Pressure Equipment
of TÜV NORD Systems GmbH & Co. KG

certifies that the company

Adams Armaturen GmbH
Baukauer Str. 55
D-44653 Herne

has been verified and recognized
as manufacturer of

**tight shut-off valves, check valves, control valves
and combined valves**

according to the rules of

AD 2000-Merkblatt HP0

Certificate-no.: 07-202-1403-HP-1578/1

The range of validity and details of the inspection can be taken from the

Report-no.: 8106510950

The company has established a product-related quality system together with personnel and equipment which assures manufacturing and testing corresponding to the technical rules

This certificate is valid until

march 2013

Tested safety

As proof of approval for various areas of application and also for the external monitoring of our production and quality assurance processes, we regularly subject our processes to certification by accredited test institutes.

It is one of our aims to continually enhance and improve our products for our customers and to deliver them with a high degree of quality and reliability. For this reason we have established a comprehensive quality management system. We regularly invest in state-of-the-art test engineering and subject our products to both in-house and external testing. To give our customers the security of knowing that our production and testing processes comply with international standards, we have them checked regularly by independent institutes.

Please feel free to ask us for further information regarding our national and international certificates if required.

- Our valves are designed in accordance with international standards such as:**
- AD technical instructions
 - ANSI
 - API
 - ASME
 - ATEX
 - BS
 - DGRL
 - DIN EN / ISO
 - GOST
 - KTA
 - MSS
 - NACE
 - RCC-M



Sealing tailored to suit requirements

The varying requirements of our customers demand various types of sealing systems. Our soft sealing and metallic sealing systems offer coordinated solutions with regard to tightness, resilience and ease of maintenance.

We are one of the few manufacturers that offer valves with the sealing system in the body seat and those with seals in the valve. The advantage is that we are able to advise our customers to find the optimal sealing solutions to suit the particular application. Whether seawater, extremely high temperatures, chemical media or other factors: with our sealing systems we offer our customers long lasting, reliable solutions for sophisticated requirements.

Seals in the body

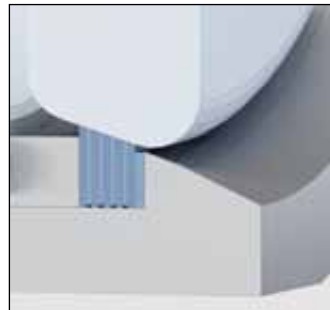

Laminated seal

The laminated seal consists of graphite and stainless steel in a sandwich construction.



Replaceable solid seal

Among other things, the solid seal has advantages for control valves: its robustness enables it to resist the high flow speeds encountered when the valve disc is almost fully closed. Apart from the replaceable solid seal for heat-affected areas (up to 600 °C) we offer a solid seal for extremely high temperatures that is not replaceable.

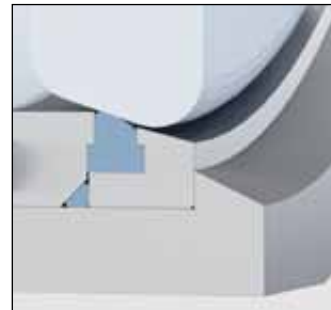

Soft seal

The soft seal is a very long lasting and therefore economical solution when dealing with non-aggressive and only moderately heated media.



L2 seal

The L2 seal is used exclusively with the MAK. This seal is particularly suitable for double-sided sealing for media with low flow speeds.

Seals on the disc



Laminated seal



Solid seal



Replaceable solid seal

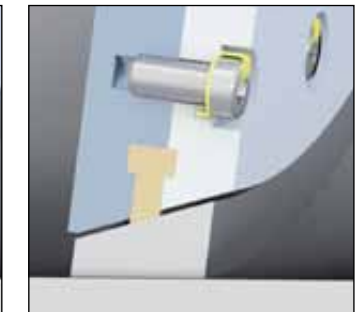

Soft seal

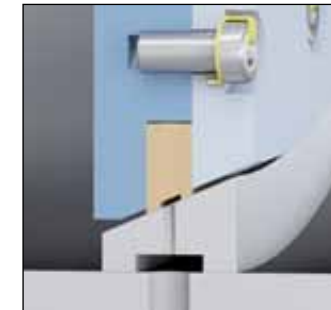

Block & bleed seal

The block & bleed technique involves using two layers of laminated seals with a space in between. This design creates two sealing levels in one valve. Drilling a hole in the body that ends exactly in this gap enables further applications to be combined, such as a leakage detector or pressurisation.

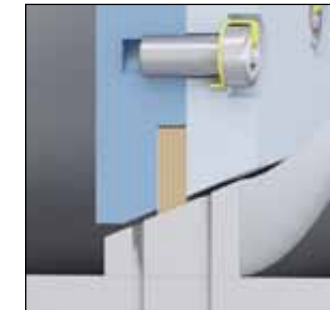

Steam purge system

The steam purge system effectively prevents residues from the medium from depositing on the surface of the seal.

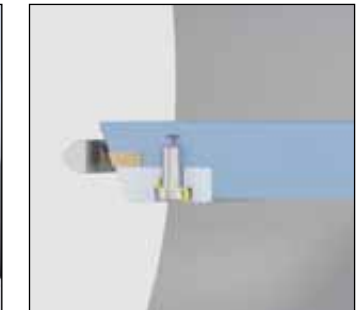

"Nose guard" seal protection

For media containing abrasive components, for example, we offer a protection system for the seal in the valve: the "nose guard" system consists of a specially designed deflector, which prevents the seal from being directly exposed to the medium flow when the valve is in the open position.

Perfectly controlled

Many of our Valves can be equipped with systems that assist the closing and damping of the closure process. It is particularly important for check valves to close quickly and still avoid water hammer while doing so.

In many industrial plants and power plants, defined closure characteristics are necessary for the valves used in order to guarantee optimal protection for equipment such as turbines or pumps. For this reason we offer our customers systems that can be individually coordinated to suit the demands of each area of application.

Drives and closure support

We offer a wide range of drives and closure supports. Whether manual, electric, hydraulic, pneumatic or with counterweights: the systems we recommend provide the best closure characteristics for your application. The use of an overrunning clutch enables the valve disc to swing freely within the defined control area, even in control valves.

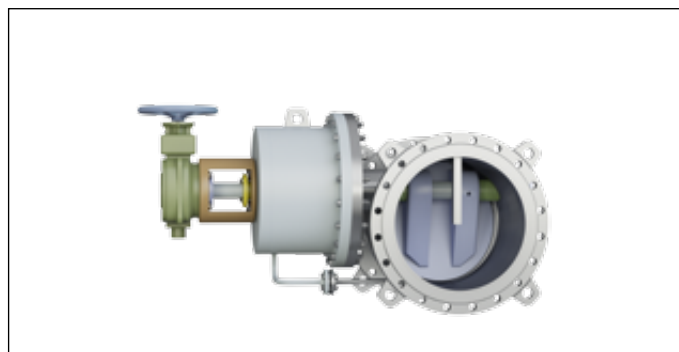

Manual drive

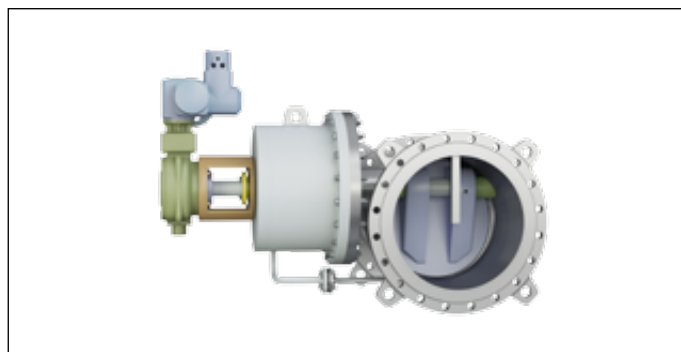

Electric drive

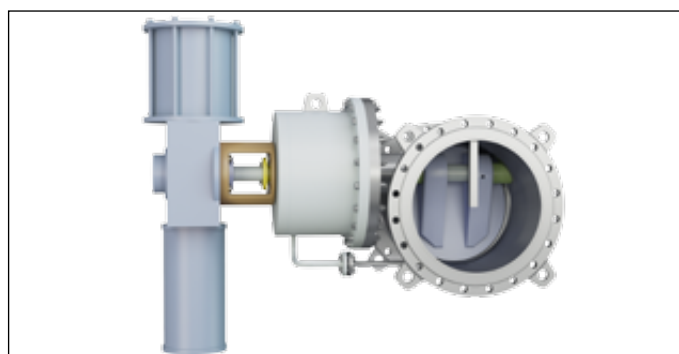

Hydraulic or pneumatic drive

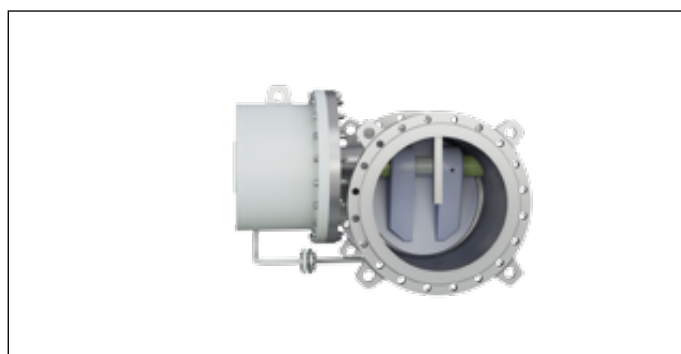

Closure support with counterweight

Damping

If a pump fails or is switched off it leads to a backflow of the medium. This results in the valve disc being accelerated by the backflow of the medium, which leads to water hammer. In order to avoid this problem as well as possible we offer damping systems for our valves that guarantee optimal control over the development of pressure surges in the pipes.

The damping systems are designed as one-level or multi-level systems. In addition to detecting single damping areas, the multi-level damping systems also individually determine their starting points. The damping characteristics can even be changed during operation, for instance if changes to the entire system make another characteristic necessary.



1970

1980

1990

2000

2010



Imprint

ADAMS Armaturen GmbH
Baukauer Str. 55
44653 Herne / Germany

Tel +49 (0)2323 209 0
Fax +49 (0)2323 209 285

www.adams-armaturen.com
info@adams-armaturen.de

As at april 2011.
All rights reserved.
Contents are subject to change.

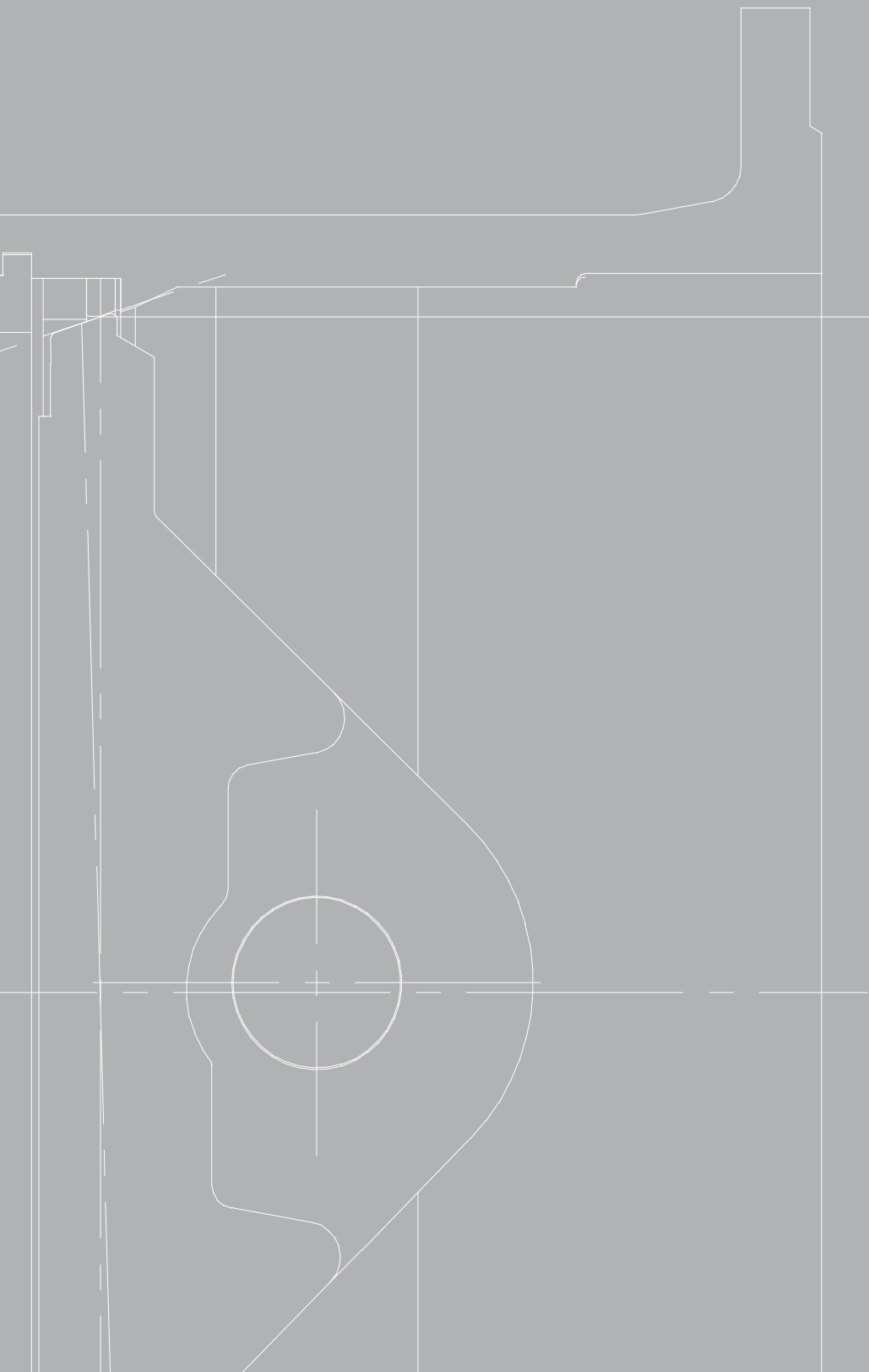

ADAMS 
Try the butterfly!